

Goods Classification and the Harmonized System (HS)

Presented by

J. A. D. A. Perera

Director of Customs

SHIPPERS' ACADEMY COLOMBO



The Harmonized System

- This is an international convention
- The convention consists 20 articles
- The Harmonized Commodity Description & Coding System. This is abbreviated as the HS
- It's a multi-purpose international nomenclature. Its main application is for customs tariff & trade statistics
- The HS is used for many other purposes such as; Rules of Origin, freight tariff, trade monitoring, etc.

- Progressively divided the goods (commodities), until the appropriate level of classification is found.
- The merchandise entering the world trade are classified according to the rules of the HS.
- This system facilitate, to accommodate all types of internationally traded goods, within a code number. This is known as the **HS code**.
- The Customs Tariff will indicate how much duty is payable on imported or exported goods.
- The HS came into force on 1st of January 1988. This was amended in 1992, 1996 , 2002, 2007.2012, & 2017.

Features of the Harmonized System

- This structure could be understood by any person
- This is achieved by providing precise instructions by way of explanatory notes & other complementary publications.
- Primarily by a set of six interpretation rules of the HS & secondly by providing legal notes specifying the scope of sections, chapters, headings & most sub-headings.

- **Sections** – The 21 sections comprise all the commodities of international trade, including every thing from live plants, animals, there products, chemicals, machinery, etc.
- **Chapters** – Under sections to get more detailed classification the sections are divided in to different chapters & sub chapters.
- **Heading numbers** – The heading number is a commodity number consisting of four figures: a four digit code. The first two digits show which chapter the commodity belongs to, & the last two show what position the commodity has within the chapter.

The Structure of the HS

- 21 sections (divided in to chapters)
- 96 chapters (divided in to headings)
- 1222 headings & 5387 subheadings.(in 2017)
- Four digit classification is called a heading
- Fifth digit and sixth digit level is called a sub heading
- Chapter 77 -- reserved for future use in the Harmonized System
- Chapter 98 & 99 -- reserved for special use by contracting parties

The HS Code

- The four digit heading numbers are generally divided in to subheadings coded with two additional digits. The subsequent **six- digit number is called a HS code.**
- The nomenclature can have even more subdivisions beyond the six-digit level of the HS, to separately identify commodities **of national or regional interest. (National subdivision -NSD)**

HS heading 01.06 other live animals

HS code 0106.11 -- Primates

- When an HS heading is not subdivided into 5th & 6th digit, the HS code is indicated with two zeroes in the last two digits.
0903.00 Mate. 0905.00 Vanilla.
- If a HS heading is subdivided in to 5th digit level, the HS code is identified with a zero in the 6th digit & it identifies as a one dash (-) subheading. 0813.10 - Apricots,

- If a HS heading is subdivided in to 6th digit level no zero is indicated in the 6th digit & this identifies as a two dash (--) sub heading.
 - ❑ 0807.11 - - water melons
- This six digit level could be subdivided in to 8 digit level, & it is called a national subheading . It is identified by three dashes.
 - ❑ 0105.11.10 --- Day-old chicks for breeding.
 - ❑ or by four dashes 8703.21.51 ---- With two-stroke petrol engines.
- Countries adopting this could make further subdivisions to their particular tariff **and statistical** needs.

2012

**69.08 Glazed
ceramic flags and
paving, hearth or wall
tiles; glazed ceramic
mosaic cubes and the
like, whether or not
on a backing.**

2017

[69.08]

2012

8432.30 - Seeders,
planters and
transplanters

2017

- Seeders, planters
and transplanters :

8432.31 -- No-till direct
seeders, planters
and transplanters

8432.39 --Other

Heading and Subheading Provisions

- Merchandise may be specifically provided for or identify by its common, commercial or technical name in an article or product description (the text to a heading or subheading) in the HS system.
- If the merchandise is not specifically provided in the Harmonized system the article description covering such merchandise is generally considered to be a “Residual provision (basket heading) by use of the phrase “**not else where specified or included**” or by the term “**other**”.
- In other words, although not all goods are specifically provided for, **all goods are classifiable & have a place in the HS**

Section I

LIVE ANIMALS; ANIMAL PRODUCTS

Notes.

- 1.- Any reference in this Section to a particular genus or species of an animal, except where the context otherwise requires, includes a reference to the young of that genus or species.
- 2.-Except where the context otherwise requires, throughout the Nomenclature any reference to "dried" products also covers products which have been dehydrated, evaporated or freeze-dried.

Chapter 1

Live animals

Note.

1.- This Chapter covers all live animals except :

- a) Fish and crustaceans, molluscs and other aquatic invertebrates, of heading 03.01, 03.06 or 03.07;
- b) Cultures of micro-organisms and other products of heading 30.02; and ;
- c) Animals of heading 95.08.

- Description. - Proper identification of the goods;
 - This is done by referring to the documents accompanying the goods ..
 - Invoice, contract, catalogues, literature, analytical reports etc...
- Examination report of the goods will also be necessary in many cases.

The classification is done on certain qualities of the commodity such as...

- Description
- Composition & technical specification
- Manner of presentation (e.g. Packed for retail sale)
- Degree of manufacture
- Function or use

- Degree of Manufacture
 - Raw material
 - Un worked products
 - Semi-finished products, & finished goods

- Usage or Function
 - Fuels
 - Medicine
 - Capital goods
 - Consumer goods

)

Legal notes.

- Legal notes are known as section notes, Chapter notes subheading notes & so on. The functions of the notes are to define the precise scope & limits of each section or a chapter .These notes form an integral part of the HS & have the same legal force.

) General Rules for The Interpretation of the HS

- *A set of 6 GRI's are provided to ensure uniform application of the HS. This provide guidance in arriving at the correct classification of the commodity within the HS.*

- *EXPLANATORY NOTES .*
 - ❖ *_There are five volumes of explanatory notes prepared for guidance of use.*

The Principles of the Six General Rules

There are only 6 General Rules.

- GRI. 1-5 concern the four-digit heading numbers.
- GRI 6 governs classification in to subheadings, i.e. six-digit HS Codes
- The purpose of the rules is to ensure the uniform and consistent application of the HS Nomenclature and to lay down principles for how the Nomenclature should be interpreted.
- The Rules are integrated in to the Nomenclature

Rules in order of Precedence

- GRI 1-4 are in order of precedence.
- Therefore when classification issues arise, the rules must be tried out in that order.
- You try out whether GRI 1 can be applied. If you can, you stop there .
- If it cannot, you go on to GRI 2 and try that out, and so on.

General rules for the interpretation of the Harmonized System

Classification of goods in the nomenclature shall be governed by the following principles:

GRI 1

The titles of sections, chapters & sub-chapters are provided for ease reference only; for legal purposes, classification shall be determined according to the terms of the headings & any relative section or chapter notes &, provided such headings or notes do not otherwise require, according to the following provisions.

GRI 1: Titles for ease of reference

- Rule 1 says that the titles of sections, chapters and sub-chapters are for ease of reference only.
- These titles apply to broad groups of goods. The descriptions can be kept short as they are specified in more detail at the lower levels of the system.

Example 1

Section xv covers base metals and articles of base metal. There are a lot of goods made from base metals that are classified under completely different sections. For example:

Machines: Section xvi
Vehicles: Section xvii
Revolvers: Section xix

Machinery and Mechanical appliances
Vehicles, ...
Arms and Ammunition

GRI 1: Titles for ease of reference

- Rule 1 says that the titles of sections, chapters and sub-chapters are for ease of reference only.
- These titles apply to broad groups of goods. The descriptions can be kept short as they are specified in more detail at the lower levels of the system.

Example 2

Chapter 44 contains ***Wood and articles of Wood*** but wooden furniture is classified under Chapter 94 ***Furniture***;

And wooden walking sticks are classified under Chapter 66 ***Umbrellas, Sun umbrellas, walking sticks***,

GRI 1: Headings and notes are binding

- Goods are to be classified according to the terms of the headings (descriptions) and the relevant Sections Notes and Chapter Notes.
- If there are no other regulations in these headings and notes, classification must be carried out according to Rules 2-5, that is the other rules that govern the four-digit heading numbers.

GRI 2

- (a) Any reference in a heading to an article shall be taken to include a reference to that article incomplete or unfinished, provided that, as presented, the incomplete or unfinished article has the essential character of the complete or finished article. It shall also be taken to include a reference to that article complete or finished (or falling to be classified as complete or finished by virtue of this rule), presented unassembled or disassembled.

GRI 2a – Unfinished can still be Finished

An article that is incomplete or unfinished is still classified as if it were complete or finished if it has the essential character of the complete or finished article.

The same applies to assembly kits.

A few examples:

A shipment of Bicycles without seats are classified in the same way as completed bicycles. There can hardly be any doubt about what the finished article will be.

Bicycles imported in parts (wheels, mudguards, saddle, frame etc.) intended for assembly either in the retail store or by the purchaser, are regarded as assembly kits and therefore classified as complete bicycles.

- Record players without the tone arm.
- DVD player without the pickup cartridge (laser eye).
- Yacht without its Propeller and drive shaft.
- A ceramic statuette without painted.

- (b) . Any reference in a heading to a material or substance shall be taken to include a reference to mixtures or combinations of that material or substance with other materials or substance. Any reference to goods of a given material or substance shall be taken to include a reference to goods consisting wholly or partly of such material or substance. The classification of goods consisting of more than one material or substance shall be according to the principles of rule 3.

GRI 2b extends the scope of the title

Rule 2b ensures that any heading that mentions a material or substance is taken to include mixtures or combinations that contain that material or substance.

05.11 Horsehair applies, consequently, even if the horsehair is part of a mixture of other materials or substances.



Chapter 5

Products of animal origin, not elsewhere specified or included

1. This Chapter does not cover :
 - (a) Edible products (other than guts, bladders and stomachs of animals, whole and pieces thereof, and animal blood, liquid or dried);
 - (b) Hides or skins (including fur skins) other than goods of heading 05.05 and parings and similar waste of raw hides or skins of heading 05.11 (Chapter 41 or 43);
 - (c) Animal textile materials, other than horsehair and horsehair waste (Section XI); or
 - (d) Prepared knots or tufts for broom or brush making (heading 96.03).
2. For the purposes of heading 05.01, the sorting of hair by length (provided the root ends and tip ends respectively are not arranged together) shall be deemed not to constitute working.
3. Throughout the Nomenclature, elephant, hippopotamus, walrus, narwhal and wild boar tusks, rhinoceros horns and the teeth of all animals are regarded as "ivory".
4. Throughout the Nomenclature, the expression "horsehair" means hair of the manes or tails of equine or bovine animals.

GRI 3

When by application of rule 2(b) or for any other reason. Goods are, *prima facie*, classifiable under two or more headings. Classification shall be classifiable effected as follows:

- ❑ (a) The heading which provides the most specific description shall be preferred to headings providing a more general description.

However, when two or more headings each refer to part only of the material or substances contained in mixed or composite goods or to part only of the items in a set put up for retail sale, those headings are to be regarded as equally specific in relation to those goods, even if one of them gives a more complete or precise description of the goods.

GRI 3: When several headings look suitable

The classification of goods that consist of several different materials, substances or parts is governed by Rule 3.

This rule is applied if two or more heading numbers might be applicable to the commodity.

GRI 3a

- In general under this criterion,
 1. A description by name is more specific than a description by class.
 2. A description that more clearly identifies a product is most specific than one which is less complete.

GRI 3a

The best description of shavers?

Electrical Shavers fit the commodity descriptions of the following heading numbers:

- 84.67 Tools for working in the hand, pneumatic, hydraulic or with self-container electric or non-electric motor.
- 85.09 Electro-mechanical domestic appliances, with self-contained electric motor.
- 85.10 Shavers, hair clippers and hair-removing appliances, with self-contained electric motor.

85.10 Contains the most precise description. Shavers are actually mentioned by name there. Headings that mention goods by name are always considered more specific than headings covering group of goods.

The best description of car carpeting?

A shipment of carpets for cars consists of tufted textile carpeting!

Should the carpeting be classified under 8708 (parts and accessories of motor vehicles) or under 5703 (where tufted carpets are mentioned by name in the description)?

The correct heading number 5703 is motivated by the fact that if goods fit a commodity description that identifies them precisely, that description is to be considered more specific than a description that identifies them less precisely.

“Parts and accessories of motor vehicles” could be almost anything!!

GRI 3 (b)

- (b) Mixtures, composite goods consisting of different materials or made up of different components, and goods put up in sets for retail sale, which cannot be classified by reference to 3 (a), shall be classified as if they consisted of the material or component which gives them their essential character, insofar as this criterion is applicable.

GRI 3b - Classify by essential character - sometimes

▪ Rule 3b prescribes that goods shall be classified under the heading number covering the material or component which gives the composite article or the set its essential character (essential component).

So Rule 3b can be used to classify;

Mixtures

Goods composed of different materials

Goods made up of different components

Goods put up in sets (for retail sale)

GRI 3b

- Essential character means...

The essential character of an article may be based on;

Volume

Quality

Quantity

Weight

Value

A material or a component making up an article can also give the article its essential character by virtue of its importance for the use of the article.

A pencil sharpener (8214) with a shavings container made of plastic (3926) belongs entirely to 8214 as the pencil sharpener gives the article its essential character.

GRI 3b – Goods put up in sets

Rule 3b defines goods put up in sets for retail sale as sets containing:

- At least two different articles belonging to different heading numbers;
- Articles that together fulfill a certain need or that have a special use;
- Articles that are packed together in the same packaging for sale in a retail store

Classify *drawing instruments*.

Drawing instruments can be seen as a set which might, for example comprise of a case of plastic sheeting (42.02) holding a ruler (90.17), a protractor (90.17), Calipers (90.17), a pencil (96.09), and a pencil sharpener (82.14).

The set contains three articles covered by heading 9017, which taken together give the set its essential character. Therefore, the drawing instruments should be classified under heading 90.17.

GRI 3b – Goods put up in sets Contd.

Rule 3b defines goods put up in sets for retail sale as sets containing:

- At least two different articles belonging to different heading numbers;
- Articles that together fulfill a certain need or that have a special use;
- Articles that are packed together in the same packaging for sale in a retail store

Hair Care Sets

A “Hair-care set” might perhaps consist of an electrical hair clipper (85.10), a comb (96.15), scissors (82.13), a brush (96.03), and a textile towel (63.02). This is all packaged in a leather case (42.02).

The Hair-care set is classified as **85.10** because the electrical hair clipper gives the article its essential character.

Toiletry sets – distributed by airlines to its passengers (During their flight or at their destination if their baggage is not available) Consisting of a rectangular fabric bag measuring 20 * 12 * 5 cm and containing;

- Disposable razor mounted on a small aerosol can of shaving foam
- Tooth brush and small tube of tooth past
- Scented handkerchief
- Pair of knitted socks
- Textile blind fold for protection from light
- Pair of year plugs

✓ Application of GRI – **1** **9605.00**

1) Sets, the components of which are intended to be used together in the preparation of a spaghetti meal consisting of a packet of uncooked spaghetti (19.02), a sachet of grated cheese (04.06) and a small tin of tomato sauce (21.03) put up in a carton.

Classification given in heading – 19.02

The rule does not, however, cover selections of products put up together and consisting, for example of :

A bottle of spirits of heading 22.08 and a bottle of wine of heading 22.04

In this case each item is to be classified separately in it's own appropriate heading

- (c) When goods cannot be classified by reference to 3(a) or 3 (b) , they shall be classified under the heading which occurs last in numerical order among those which equally merit consideration.

Rechargeable

MULTI-FUNCTION LANTERN



85.13

Portable electric lamps designed to function by their own source of energy (for example, dry batteries, accumulators, magnetos), other than lighting equipment of heading 85.12.

85.27

Reception apparatus for radio-broadcasting, whether or not combined, in the same housing, with sound recording or reproducing apparatus or a clock.

GRI 4

- Goods which cannot be classified in accordance with the above rule shall be classified under the heading appropriate to the goods to which they are most akin.

GRI 4

- If goods cannot be classified according to GRI 1 to 3, then resort must be made to GRI 4.
- This rule should be applied very infrequently as GRI 1 to 3 will cover the classification of all most all goods.
- When applying this rule, it is on the “kinship” and it depends on such factors as description, character, purpose or indented use, designation, production process and the nature of the goods.

GRI5 - In addition to the foregoing provisions, the following rules shall apply in respect of the goods referred to therein:

- (a) Camera cases, musical instrument cases, gun cases, drawing instrument cases, necklace cases and similar containers, specially shaped or fitted to contain a specific article or set of articles, suitable for long-term use and presented with the article for which they are intended, shall be classified with such articles when of kind normally sold with. This rule does not, however, apply to containers which give the whole its essential character.

GRI 5a

Containers with no number of their own

Specially shaped containers (but not packagings) are in principle covered by the same heading as the goods they are intended to protect. All the following conditions must be fulfilled, though:

1. The cases:

Must be specially shaped or fitted to contain a specific article or set of articles;

Must be intended to last for as long as the articles they are intended for;

Must be presented together with the articles they are intended for (even if for transport reasons they are packed separately);

Must be sold together with the articles they are intended for;

Must not give the goods their essential character (see Rule 3b).

- (b) Subject to the provisions of GIR 5 (a) above, packing materials and containers presented with the goods therein shall be classified with the goods if they are of a kind normally used for packing such goods. However, this provision is not binding when such packing materials or packing containers are clearly suitable for repetitive use.

GRI 6

For legal purpose, the classification of goods in the subheadings of a heading shall be determined to the terms of those subheadings and any related subheading notes and, *mutatis mutandis*, to the above rules, on the understanding that only subheading at the same level are comparable. For the purpose of this rule the relative section and chapter notes also apply, unless the context otherwise requires.

GRI 6

- It prescribes that for legal purpose GRI 1 to 5 govern, mutatis and mutandis (or with necessary changes) classifications at subheading levels within the same heading.
- Goods are to be classified at equal subheading levels (that is at the same digit level) within the same heading under the subheading that most specifically describes or identifies them.
- Only subheadings at the same level within the same heading are comparable.

Table of Contents

SECTION I

LIVE ANIMALS; ANIMAL PRODUCTS

Notes.

1. Live animals.
2. Meat and edible meat offal.
3. Fish and crustaceans, molluscs and other aquatic invertebrates.

Chapter 3

Fish and crustaceans, molluscs and other aquatic invertebrates

- **Notes.**

1. This Chapter does not cover :

a) Mammals of heading 01.06;

b) Meat of mammals of heading 01.06 (heading 02.08 or 02.10);

c) Fish (including livers and roes thereof) or crustaceans, molluscs or other aquatic invertebrates, dead and unfit or unsuitable for human consumption by reason of either their species or their condition (Chapter 5); flours, meals or pellets of fish or of crustaceans, molluscs or other aquatic invertebrates, unfit for human consumption (heading 23.01); or

d) Caviar or caviar substitutes prepared from fish eggs (heading 16.04)

4. Dairy produce; birds' eggs; natural honey; edible products of animal origin, not elsewhere specified or included.

Chapter 4

**Dairy produce; birds' eggs; natural honey;
edible products of animal origin,
not elsewhere specified or included**

Notes.

1. The expression "milk" means full cream milk or partially or completely skimmed milk.

2. For the purposes of heading 04.05 :

- (a) The term "butter" means natural butter, whey butter or recombined butter (fresh, salted or rancid, including canned butter) derived exclusively from milk, with a milk fat content of 80% or more but not more than 95% by weight, a maximum milk solids-not-fat content of 2% by weight and a maximum water content of 16% by weight. Butter does not contain added emulsifiers, but may contain sodium chloride, food colors, neutralizing salts and cultures of harmless lactic-acid-producing bacteria.

- (b) The expression "dairy spreads" means a spreadable emulsion of the water-in-oil type, containing milk fat as the only fat in the product, with a milk fat content of 39% or more but less than 80% by weight.

04.03		Buttermilk, curdled milk and cream, yogurt, kephir and other fermented or acidified milk and cream, whether or not concentrated or containing added sugar or other sweetening matter or flavoured or containing added fruit, nuts or cocoa.		
	0403.10	- Yogurt		kg
	0403.90	- Other		kg
04.09	0409.00	Natural honey.		kg
04.10	0410.00	Edible products of animal origin, not elsewhere specified or included.		kg

=

Chapter 5
**Products of animal origin,
not elsewhere specified or included**

Notes.

1. This Chapter does not cover :
 - a) Edible products (other than guts, bladders and stomachs of animals, whole and pieces thereof, and animal blood, liquid or dried);
 - b) Hides or skins (including fur skins) other than goods of heading 05.05 and parings and similar waste of raw hides or skins of heading 05.11 (Chapter 41 or 43);
 - c) Animal textile materials, other than horsehair and horsehair waste (Section XI); or
 - d) Prepared knots or tufts for broom or brush making (heading 96.03).

Section II

VEGETABLE PRODUCTS

- **Note.**
- 1.- In this Section the term "pellets " means products which have been agglomerated either directly by compression or by the addition of a binder in a proportion not exceeding 3 % by weight.

Chapter 6

Live trees and other plants; bulbs, roots and the like; cut flowers and ornamental foliage

- **Notes.**
- 1.- Subject to the second part of heading 06.01, this Chapter covers only live trees and goods (including seedling vegetables) of a kind commonly supplied by nursery gardeners or florists for planting or for ornamental use; nevertheless it does not include potatoes, onions, shallots, garlic or other products of Chapter 7.
- 2.- Any reference in heading 06.03 or 06.04 to goods of any kind shall be construed as including a reference to bouquets, floral baskets, wreaths and similar articles made wholly or partly of goods of that kind, account not being taken of accessories of other materials. However, these headings do not include collages or similar decorative plaques of heading 97.01.

SECTION II

VEGETABLE PRODUCTS

Chapters.

6. Live trees and other plants; bulbs, roots and the like; cut flowers and ornamental foliage.
7. Edible vegetables and certain roots and tubers.
8. Edible fruit and nuts; peel of citrus fruit or melons.
9. Coffee, tea, mate and spices.
10. Cereals.
11. Products of the milling industry; malt; starches; insulin; wheat gluten.
12. Oil seeds and oleaginous fruits; miscellaneous grains, seeds and fruit; industrial or medicinal plants; straw and fodder.

- Note. 3 to chapter 12

- 3.- For the purposes of heading 12.09, beet seeds, grass and other herbage seeds, seeds of ornamental flowers, vegetable seeds, seeds of forest trees, seeds of fruit trees, seeds of vetches (other than those of the species *Vicia faba*) or of lupines are to be regarded as "seeds of a kind used for sowing".
- Heading 12.09 does not, however, apply to the following even if for sowing :
 - (a) Leguminous vegetables or sweet corn (Chapter 7);
 - (b) Spices or other products of Chapter 9;
 - (c) Cereals (Chapter 10); or
 - (d) Products of headings 12.01 to 12.07 or 12.11.
- ***{07.08 Leguminous vegetables, shelled or unshelled, fresh or chilled.***
- ***07.13 Dried leguminous vegetables, shelled , whether or not skinned or split (+).}***

12.10		Hop cones, fresh or dried, whether or not ground, powdered or in the form of pellets; lupulin.
	1210.10	- Hop cones, neither ground nor powdered nor in the form of pellets
	1210.20	- Hop cones, ground, powdered or in the form of pellets; lupulin
12.11		Plants and parts of plants (including seeds and fruits), of a kind used primarily in perfumery, in pharmacy or for insecticidal, fungicidal or similar purposes, fresh or dried, whether or not cut, crushed or powdered.
	1211.20	- Ginseng roots
	1211.30	- Coca leaf
	1211.40	- Poppy straw
	1211.90	- Other

Chapter 13

Lac; gums, resins and other vegetable saps and extracts

Note.

1. Heading 13.02 applies, inter alia, to liquorice extract and extract of pyrethrum, extract of hops, extract of aloes and opium.

The heading does not apply to :

- a) Liquorice extract containing more than 10 % by weight of sucrose or put up as confectionery (heading 17.04);
- b) Malt extract (heading 19.01);
- c) Extracts of coffee, tea or mate (heading 21.01);
- d) Vegetable saps or extracts constituting alcoholic beverages (Chapter 22);
- e) Camphor, glycyrrhizin or other products of heading 29.14 or 29.38;

- (f) Concentrates of poppy straw containing not less than 50 % by weight of alkaloids (heading 29.39);
- (g) Medicaments of heading 30.03 or 30.04 or blood-grouping reagents (heading 30.06);
- (h) Tanning or dyeing extracts (heading 32.01 or 32.03);
- (ij) Essential oils, concretes, absolutes, resinoids, extracted oleoresins, aqueous distillates or aqueous solutions of essential oils or preparations based on odoriferous substances of a kind used for the manufacture of beverages (Chapter 33); or
- (k) Natural rubber, balata, gutta-percha, guayule, chicle or similar natural gums (heading 40.01).

14. Vegetable plaiting materials; vegetable products not elsewhere specified or included.

SECTION III

ANIMAL OR VEGETABLE FATS AND OILS AND THEIR CLEAVAGE PRODUCTS; PREPARED EDIBLE FATS; ANIMAL OR VEGETABLE WAXES

15. Animal or vegetable fats and oils and their cleavage products; prepared edible fats; animal or vegetable waxes.

15.04 Fats and oils and their fractions, of fish or marine mammals, whether or not refined, but not chemically modified :

1504.10 - Fish-liver oils and their fractions

1504.20 - Fats and oils and their fractions, of fish, other than liver oils

1504.30 - Fats and oils and their fractions, of marine mammals :

Pure Cod Liver oil put up in capsules of 1000mg each. Put up in measured doses & in packing's for retail sale. Used as a food supplement for the maintenance for general health & well-being.

1504.10

***SALMON OIL, PUT UP IN GELATINE CAPSULES OF 1000 MG,
ENRICHED WITH AN ACTIVE
OMEGA-3 NUTRITIONAL COMPLEX (EICOSAPENTAENOIC ACID (180
MG) AND DOCOSAHEXAENOIC ACID (120 MG)) * (THE PRODUCT IS
CLAIMED TO SUPPORT HEALTHY HEART AND BRAIN FUNCTION / IT
IS PRESENTED IN BOXES CONTAINING 120 CAPSULES)***

1504.20

PRODUCT DESCRIPTION : EDIBLE PREPARATION OF ANIMAL AND VEGETABLE FATS, PRESENTED AS AN

EMULSION OF THE 'WATER-IN-OIL' TYPE IN SOLID FORM, RESEMBLING BUTTER IN APPEARANCE, CONSISTENCY AND COLOUR * (COMPOSITION : VEGETABLE FATS 85.1 % OF THE TOTAL AMOUNT OF FATS IN THE PRODUCT, MILK FAT 14.9 % OF THE TOTAL AMOUNT OF FATS IN THE PRODUCTS WATER (15.84 %), BUTTERMILK POWDER, EMULSIFIER, FLAVOURING AND COLOURING MATTERS (2.16 %) * (THE PREPARATION IS PUT UP IN BLOCKS OF 200 G EACH)

1517.10

SECTION IV

PREPARED FOODSTUFFS; BEVERAGES, SPIRITS AND VINEGAR; TOBACCO AND MANUFACTURED TOBACCO SUBSTITUTES

Section notes.

16. Preparations of meat, of fish or of crustaceans, molluscs or other aquatic invertebrates.

***PRODUCT DESCRIPTION : PRODUCT REFERRED TO AS 'HAM IMPERIAL' *
(MANUFACTURING PROCESS :***

THE MEAT IS INJECTED WITH BRINE CONTAINING WATER, SALT, SPICES, NITRATES, PHOSPHATES AND ASCORBATE / AFTER CUTTING AND TRIMMING THE MEAT PRODUCT AT ISSUE IS COOKED AT HIGH TEMPERATURE INSTEAM OVENS UNTIL IT REACHES AN INTERNAL TEMPERATURE OF 75° C / FINALLY, IT ISSMOKED IN OVENS FOR IMPROVED PRESERVATION / IT IS PUT UP IN SEALED PLASTIC BAGS WITH A NET WEIGHT OF APPROX. 200 G)

1602.41 -- Hams and cuts thereof

1602.41

Chapter 17

Sugars and sugar confectionery

Note.

1.- This Chapter does not cover :

- (a) Sugar confectionery containing cocoa (heading 18.06);
- (b) Chemically pure sugars (other than sucrose, lactose, maltose, glucose and fructose) or other products of heading 29.40; or
- (c) Medicaments or other products of Chapter 30.

Subheading Note.

- 1.- For the purposes of subheadings 1701.11 and 1701.12, "raw sugar" means sugar whose content of sucrose by weight, in the dry state, corresponds to a polarimeter reading of less than 99.5 °.

1702.90	-	Other, including invert sugar and other sugar and sugar syrup and sugar syrup blends containing in the dry state 50% by weight of fructose :		
1702.90.10	---	Brewing sugar, artificial honey		kg
	---	Varieties of Sakkara, jaggery		
1702.90.21	---	Sakkara (suger cane jaggery)		kg
1702.90.22	---	Kithul jaggery		kg
1702.90.29	---	Other		kg
1702.90.30	---	Kithul treacle		kg
1702.90.90	---	Other		kg

17.04		Sugar confectionery (including white chocolate), not containing cocoa.
	1704.10	- Chewing gum, whether or not sugar-coated :
	1704.10.10	--- In retail packaging of 1 kg or less
	1704.10.90	--- Other
	1704.90	- Other :
	1704.90.10	--- In retail packaging of 1 kg or less
	1704.90.90	--- Other

PRODUCT REFERRED TO AS '**FRUIT FLAVOURED WITH NATA DE COCO JELLY**' (IT CONSISTS OF WATER, SUGAR, CARRAGEENAN, CITRIC ACID, POTASSIUM CITRATE, FRUIT FLAVOURING, SODIUM BENZOATE, FOOD COLOURING MATTER AND NATA DE COCO ('COCONUT GEL') / THE JELLY IS PUT UP IN A TRANSPARENT PLASTIC CUP OF A NET CONTENT OF 30 G)

1704.90

PRODUCT REFERRED TO AS '**YOGO ICE**' (IT CONSISTS OF WATER (74 %), SUGAR (19 %), CARBOXYMETHYL CELLULOSE (0.3 %), CONCENTRATED FRUIT JUICE (5 %), MILK POWDER (1 %), FLAVOURING, CITRIC ACID AND COLOURING MATTER / THE PRODUCT IS PUT UP IN A TRANSPARENT PLASTIC CYLINDER OF A NET CONTENT OF 45 ML)

1704.90

18. Cocoa and cocoa preparations.

Chapter 18 Cocoa and Cocoa preparations

Notes.

1. This Chapter does not cover the preparations of heading 04.03, 19.01, 19.04, 19.05, 21.05, 22.02, 22.08, 30.03 or 30.04.
2. Heading 18.06 includes sugar confectionery containing cocoa and, subject to Note 1 to this Chapter, other food preparations containing cocoa.

18.05	1805.00	Cocoa powder, not containing added sugar or other sweetening matter.		kg
18.06		Chocolate and other food preparations containing cocoa (+).		
	1806.10	- Cocoa powder, containing added sugar or other sweetening matter		kg
	1806.20	- Other preparations in blocks, slabs or bars weighing more than 2 kg or in liquid, paste, powder, granular or other bulk form in containers or immediate packings, of a content exceeding 2 kg		kg
		- Other, in blocks, slabs or bars :		

18.06		Chocolate and other food preparations containing cocoa (+).
	1806.10	- Cocoa powder, containing added sugar or other sweetening matter
	1806.20	- Other preparations in blocks, slabs or bars weighing more than 2 kg or in liquid, paste, powder, granular or other bulk form in containers or immediate packing's, of a content exceeding 2 kg
		- Other, in blocks, slabs or bars :
	1806.31	-- Filled
	1806.32	-- Not filled
	1806.90	- Other

Classify a Ferrero Rocher –Hazelnut Chocolate and a Kandos Fruit and Nut Chocolate , shown bellow.
-Product Description.



19. Preparations of cereals, flour, starch or milk; pastrycooks' products.

20. Preparations of vegetables, fruit, nuts or other parts of plants.

Chapter 20

Preparations of vegetables, fruit, nuts or other parts of plants

Notes.

1. This Chapter does not cover :

- a) Vegetables, fruit or nuts, prepared or preserved by the processes specified in Chapter 7, 8 or 11;
- b) Food preparations containing more than 20 % by weight of sausage, meat, meat offal, blood, fish or crustaceans, molluscs or other aquatic invertebrates, or any combination thereof (Chapter 16);
- c) Bakers' wares and other products of heading 19.05; or
- d) Homogenized composite food preparations of heading 21.04.

2. Headings 20.07 and 20.08 do not apply to fruit jellies, fruit pastes, sugar-coated almonds or the like in the form of sugar confectionery (heading 17.04) or chocolate confectionery (heading 18.06).
3. Headings 20.01, 20.04 and 20.05 cover, as the case may be, only those products of Chapter 7 or of heading 11.05 or 11.06 (other than flour, meal and powder of the products of Chapter 8) which have been prepared or preserved by processes other than those referred to in Note 1 (a).
4. Tomato juice the dry weight content of which is 7 % or more is to be classified in heading 20.02.
5. For the purposes of heading 20.07, the expression "obtained by cooking" means obtained by heat treatment at atmospheric pressure or under reduced pressure to increase the viscosity of a product through reduction of water content or other means.

21. Miscellaneous edible preparations.

22. Beverages, spirits and vinegar.

23. Residues and waste from the food industries; prepared animal fodder.

24. Tobacco and manufactured tobacco substitutes.

Chapter 21

Miscellaneous edible preparations

21.01 Extracts, essences and concentrates, of coffee, tea or mate and preparations with a basis of these products or with a basis of coffee, tea or mate; roasted chicory and other roasted coffee substitutes, and extracts, essences and concentrates thereof.

- Extracts, essences and concentrates, of coffee, and preparations with a basis of these extracts, essences or concentrates, or with a basis of coffee :

2101.11 -- Extracts, essences and concentrates

2101.12 -- Preparations with a basis of extracts, essences or concentrates or with a basis of coffee

2101.20 - Extracts, essences and concentrates, of tea or mate, and preparations with a basis of these extracts, essences or concentrates or with a basis of tea or mate :

---Instant tea , certified by Sri Lanka Tea Board as wholly of Sri Lankan origin:

2101.20.11 ---- In immediate packing of a content not exceeding 4gr.

2101.20.12 ---- In immediate packing of a content exceeding 4 gr but not exceeding 1 kg.

Low fat butter- milk fat 38.5%, water 52.4%, sodium caseinate 05%, & small quantities of salt, emulsifiers and thickening or gelling agent, used as a dairy spread. **2106.90**

- **Aloe vera Tablets** –(in a 60 tablet container). Containing- Aloe vera powder 03%, & excipients: Calcium hydrogen phosphate, purified talc, magnesium stearate, hypromellose & propylene glycol, Used as a nutritional supplement, to help build resistance common cold, to give relief from stomach disorders such as constipation & indigestion, **2106.90**

POWER HORSE

***PRODUCT DESCRIPTION : ENERGY DRINK
(CARBONATED BEVERAGE) PUT UP IN 250 ML CANS***

(INGREDIENTS (100 ML) : TAURINE (400 MG),
GLUCORONOLACTONE (240 MG),
CAFFEINE (32 MG), SUCROSE (8.6 MG), GLUCOSE (2.1
MG), INOSITOL (20 MG),
VITAMIN_B12 (0.0002 MG), VITAMIN_B2 (0.06 MG), VITAMIN
B6 (2 MG), CAPANTHOTHENATE
(2.2 MG) AND NIACIN (8 MG))

:

The Secretariat is of the view that headings 22.02 and 30.04 .

2202.10

.

Aloe Vera Drinking Gel_ In the form of a liquid, (e.g. , 1 Liter)

01 .Containing 99.7 % pure Aloe vera gel & small amount of Sodium Benzoate , Potassium sorbate , & citric acid .

It is used as a health drink (25 to 50 ml daily) and helps to provide a wide range of vitamins ,minerals, enzymes , & amino acids :

it is claimed in the product packaging or literature to help build resistance to the common cold & to give relief from stomach disorders such as constipation & indigestions. 2202.90

02. **Non Alcoholic Beverage.** Consisting of Coconut Juice (coconut water) 80% , water, sugar , citric acid & potassium metabisulphite. For retail sale in cans of 400 ml. 2202.90

SECTION V
MINERAL PRODUCTS

25. Salt; sulphur; earths and stone; plastering materials, lime and cement.

25.09	2509.00	Chalk.
25.15		Marble, travertine, ecaussine and other calcareous monumental or building stone of an apparent specific gravity of 2.5 or more, and alabaster, whether or not roughly trimmed or merely cut, by sawing or otherwise, into blocks or slabs of a rectangular (including square) shape (+).
		- Marble and travertine :
	2515.11	-- Crude or roughly trimmed
	2515.12	-- Merely cut, by sawing or otherwise, into blocks or slabs of a rectangular (including square) shape
	2515.20	- Ecaussine and other calcareous monumental or building stone; alabaster

25.16		Granite, prophry, basalt, sandstone and other monu-mental or building stone, whether or not roughly trimmed or merely cut, by sawing or otherwise, into blocks or slabs of a rectangular (including square) shape (+).
		- Granite :
	2516.11	-- Crude or roughly trimmed
	2516.12	-- Merely cut, by sawing or otherwise, into blocks or slabs of a rectangular (including square) shape
	2516.20	- Sandstone
25.17		Pebbles, gravel, broken or crushed stone, of a kind commonly used for concrete aggregates, for road metalling or for railway or other ballast, shingle and flint, whether or not heat-treated; macadam of slag, dross or similar industrial waste, whether or not incorporating the materials cited in the first part of the heading; tarred macadam; granules, chippings and powder, of stones of heading 25.15 or 25.16, whether or not heat-treated.
	2517.10	- Pebbles, gravel, broken or crushed stone, of a kind commonly used for concrete aggregates, for road metalling or for railway or other ballast, shingle and flint, whether or not heat-treated
	2517.20	- Macadam of slag, dross or similar industrial waste, whether or not incorporating the materials cited in subheading 2517.10
	2517.30	- Tarred macadam
		- Granules, chippings and powder, of stones of heading 25.15 or 25.16, whether or not heat-treated:
	2517.41	-- Of marble
	2517.49	-- Other

25.21	2521.00	Limestone flux; limestone and other calcareous stone, of a kind used for the manufacture of lime or cement.
-------	---------	---

26. Ores, slag and ash.

27. Mineral fuels, mineral oils and products of their distillation;
bituminous substances; mineral waxes.

Chapter 27

Mineral fuels, mineral oils and products of their distillation; bituminous substances; mineral waxes

Notes.

1. This Chapter does not cover :
 - a) Separate chemically defined organic compounds, other than pure methane and propane which are to be classified in heading 27.11;
 - b) Medicaments of heading 30.03 or 30.04; or
 - c) Mixed unsaturated hydrocarbons of heading 33.01, 33.02 or 38.05.

27.10		Petroleum oils and oils obtained from bituminous minerals, other than crude; preparations not elsewhere specified or included, containing by weight 70% or more of petroleum oils or of oils obtained from bituminous minerals, these oils being the basic constituents of the preparations; waste oils.
		- Petroleum oils and oils obtained from bituminous minerals (other than crude) and preparations not elsewhere specified or included, containing by weight 70% or more of petroleum oils or of oils obtained from bituminous minerals, these oils being the basic constituents of the preparations, other than waste oils :
	2710.11	-- Light oils and preparations :
	2710.11.10	--- Aviation spirit
	2710.11.20	--- Petrol
	2710.11.30	--- Motor spirit other than petrol
	2710.11.40	--- Spirit type jet fuel
	2710.11.90	--- Other
	2710.19	-- Other :
	2710.19.10	--- Kerosene other than kerosene type jet fuel

	2710.19.20	---	Kerosene type jet fuel
	2710.19.30	---	Other medium oils and preparations
	2710.19.40	---	Gas oil / Diesel
	2710.19.50	---	Narrow boiling range oils of distillation range not exceeding a span of 50 ⁰ C and the flash point above 70 ⁰ C
	2710.19.60	---	Fuel oil
	2710.19.70	---	Lubricating oils (Base-oils) for the preparation of lubricants
	2710.19.80	---	Lubricants
	2710.19.90	---	Other
		-	Waste oils :
	2710.91	--	Containing polychlorinated biphenyls (PCBs), polychlorinated terphenyls (PCTs) or polybrominated biphenyls (PBBs)
	2710.99	--	Other

34.03 Lubricating preparations (including cutting-oil preparations, bolt or nut release preparations, anti-rust or anti-corrosion preparations and mould release preparations, based on lubricants) and preparations of a kind used for the oil or grease treatment of textile materials, leather, furskins or other materials, **but excluding** preparations containing, as basis constituents, **70% or more by weight of petroleum oils or of oils obtained from bituminous minerals.**

38.19

3819.00 Hydraulic brake fluids and other prepared liquids for hydraulic transmission, **not containing or containing less than 70% by weight of petroleum oils or oils obtained from bituminous minerals.**

3820

3820.00 Anti-freezing preparations and prepared de-icing fluids.

SECTION VI

PRODUCTS OF THE CHEMICAL OR ALLIED INDUSTRIES

Section notes.

28. Inorganic chemicals; organic or inorganic compounds of precious metals, of rare-earth metals, of radioactive elements or of isotopes.

28.36		Carbonates; peroxocarbonates (percarbonates); commercial ammonium carbonate containing ammonium carbamate.
	2836.20	- Disodium carbonate
	2836.30	- Sodium hydrogencarbonate (sodium bicarbonate)
	2836.40	- Potassium carbonates
	2836.50	- Calcium carbonate
	2836.60	- Barium carbonate
		- Other :
	2836.91	-- Lithium carbonates
	2836.92	-- Strontium carbonate
	2836.99	-- Other

(4) **Precipitated calcium carbonate.** Precipitated calcium carbonate (CaCO_3) included in this heading results from the treatment of solutions of calcium salts with carbon dioxide. Used as an extender, in the preparation of toothpastes and face-powder, in medicine (treatment of rickets), etc.

The heading **excludes** natural limestone (**Chapter 25**) and chalk (natural calcium carbonate), whether or not washed and ground (**heading 25.09**) and calcium carbonate in powder form, the particles of which are coated with a water-repellent film of fatty acids (e.g., stearic acid) (**heading 38.24**).

(E.N page VI-2836-2)

29. Organic chemicals

30. Pharmaceutical products

Chapter 30

Pharmaceutical products

Notes.

This Chapter does not cover :

- a) Foods or beverages (such as dietetic, diabetic or fortified foods, food supplements, tonic beverages and mineral waters), other than nutritional preparations for intravenous administration (Section IV);
- b) Plasters specially calcined or finely ground for use in dentistry (heading 25.20);
- c) Aqueous distillates or aqueous solutions of essential oils, suitable for medicinal uses (heading 33.01);
- d) Preparations of headings 33.03 to 33.07, even if they have therapeutic or prophylactic properties;
- e) Soap or other products of heading 34.01 containing added medicaments;
- f) Preparations with a basis of plaster for use in dentistry (heading 34.07); or
- g) Blood albumin not prepared for therapeutic or prophylactic uses (heading 35.02).

31. Fertilizers

32. Tanning or dyeing extracts; tannins and their derivatives; dyes, pigments and other coloring matter; paints and varnishes; putty and other mastics; inks.

33. Essential oils and resinoids; perfumery, cosmetic or toilet preparations.

Chapter 33

Essential oils and resinoids; perfumery, cosmetic or toilet preparations

Notes.

- 1 This Chapter does not cover :
 - (a) Natural oleoresins or vegetable extracts of heading 13.01 or 13.02;
 - (b) Soap or other products of heading 34.01; or
 - (c) Gum, wood or sulphate turpentine or other products of heading 38.05.

2. The expression "odoriferous substances" in heading 33.02 refers only to the substances of heading 33.01, to odoriferous constituents isolated from those substances or to synthetic aromatics.

3. Headings 33.03 to 33.07 apply, *inter alia*, to products, whether or not mixed (other than aqueous distillates and aqueous solutions of essential oils), suitable for use as goods of these headings and put up in packing's of a kind sold by retail for such use.

4. The expression "perfumery, cosmetic or toilet preparations" in heading 33.07 applies, *inter alia*, to the following products: scented sachets; odoriferous preparations which operate by burning; perfumed papers and papers impregnated or coated with cosmetics; contact lens or artificial eye solutions; wadding, felt and nonwovens, impregnated, coated or covered with perfume or cosmetics; animal toilet preparations.

33.03 3303.00 Perfumes and toilet waters

33.04 Beauty or make-up preparations and preparations for the care of the skin (other than medicaments), including sunscreen or sun tan preparations; manicure or pedicure preparations.

3304.10 - Lip make-up preparations

3304.20 - Eye make-up preparations

3304.30 - Manicure or pedicure preparations

- other :

3304.91 - -Powders, whether or not compressed

3304.99 - - Other

33.05		Preparations for use on the hair.
	3305.10	- Shampoos
	3305.20	- Preparations for permanent waving or straightening
	3305.30	- Hair lacquers
	3305.90	- Other

POLYTAR AF

***PRODUCT DESCRIPTION : ANTI-FUNGAL HAIR
PREPARATION INDICATED FOR THE TREATMENT OF
DANDRUFF, PSORIASIS AND SEBORRHEIC DERMATITIS
(IT CONTAINS ZINC
PYRITHIONE (1 %) AND A TAR BLEND (PINE TAR, CADE
OIL, COAL TAR SOLUTION,
ARCHIS OIL AND AN EXTRACT OF COAL TAR) IN A
SHAMPOO BASE) * (IT IS PUT UP
IN A 150 ML FLASK)***

3305.10

33.07		Pre-shave, shaving or after-shave preparations, personal deodorants, bath preparations, depilatories and other perfumery, cosmetic or toilet preparations not elsewhere specified or included; prepared room deodorisers, whether or not perfumed or having disinfectant properties.
	3307.10	- Pre-shave, shaving or after-shave preparation
	3307.20	- Personal deodorants and anti-perspirants
	3307.30	- Perfumed bath salts and other bath preparations
		- Preparations for perfuming or deodorizing rooms, including odoriferous preparations used during religious rites :
	3307.41	-- "Agarbatti" and other odoriferous preparation which operate by burning
	3307.49	-- Other
	3307.90	- Other :
	3307.90.10	--- Contact lens solutions
	3307.90.90	--- Other

Chapter 34

Soap, organic surface-active agents, washing preparations, lubricating preparations, artificial waxes, prepared waxes, polishing or scouring preparations, candles and similar articles, modeling pastes, "dental waxes" and dental preparations with a basis of plaster.

Notes.

1. This Chapter does not cover :
 - a) Edible mixtures or preparations of animal or vegetable fats or oils of a kind used as mould release preparations (heading 15.17);
 - b) Separate chemically defined compounds; or
 - c) Shampoos, dentifrices, shaving creams and foams, or bath preparations, containing soap or other organic surface- active agents (heading 33.05, 33.06 or 33.07).

34.03		Lubricating preparations (including cutting-oil preparations, bolt or nut release preparations, anti-rust or anti-corrosion preparations and mould release preparations, based on lubricants) and preparations of a kind used for the oil or grease treatment of textile materials, leather, furskins or other materials, but excluding preparations containing, as basis constituents, 70% or more by weight of petroleum oils or of oils obtained from bituminous minerals.
		- Containing petroleum oils or oils obtained from bituminous minerals :
	3403.11	-- Preparations for the treatment of textile materials, leather, furskins or other materials
	3403.19	-- Other
		- Other :
	3403.91	-- Preparations for the treatment of textile materials, leather, furskins or other materials
	3403.99	-- Other
34.06	3406.00	Candles tapers and the like.

34.03 Lubricating preparations (including cutting-oil preparations, bolt or nut release preparations, anti-rust or anti-corrosion preparations and mould release preparations, based on lubricants) and preparations of a kind used for the oil or grease treatment of textile materials, leather, furskins or other materials, but excluding preparations containing, as basis constituents, 70% or more by weight of petroleum oils or of oils obtained from bituminous minerals.

	-	Containing petroleum oils or oils obtained from bituminous minerals :
3403.11	--	Preparations for the treatment of textile materials, leather, furskins or other materials
3403.19	--	Other
3403.19.10	---	Lubricants used for motor vehicles
3403.19.90	---	Other
	-	Other :
3403.91	--	Preparations for the treatment of textile materials, leather, furskins or other materials
3403.99	--	Other
3403.99.10	---	Lubricants used for motor vehicles
3403.99.90	---	Other

34.03

Lubricating preparations (including cutting-oil preparations, bolt or nut release preparations, anti-rust or anti-corrosion preparations and mould release preparations, based on lubricants) and preparations of a kind used for the oil or grease treatment of textile materials, leather, furskins or other materials, but excluding preparations containing, as basis constituents, 70% or more by weight of petroleum oils or of oils obtained from bituminous minerals.

38.18

3818.00 Chemical elements doped for use in electronics, in the form of discs, wafers or similar forms; chemical compounds doped for use in electronics.

38.19

3819.00 Hydraulic brake fluids and other prepare liquids for hydraulic transmission, not containing or containing less than 70% by weight of petroleum oils or oils obtained from bituminous minerals.

35. Albuminoidal substances; modified starches; glues; enzymes.

36. Explosives; pyrotechnic products; matches; pyrophoric alloys;
certain combustible preparations.

36.04		Fireworks, signalling flares, rain rockets, fog signals and other pyrotechnic articles.
	3604.10	- Fireworks
	3604.90	- Other
36.05	3605.00	Matches, other than pyrotechnic articles of heading 36.04.

37. Photographic or cinematographic goods

38. Miscellaneous chemical products

TRADE MARK : DRIWATER

**PRODUCT DESCRIPTION : WATER PUT UP IN GEL FORM * (THE
PRODUCT CONTAINS 97.85 % WATER, 2 %**

CELLULOSE GUM AND 0.15 % ALUMINIUM SULPHATE / IT IS PACKAGED
IN A PLASTIC CASING, APPROXIMATELY 30 CM IN LENGTH AND
7.5 CM IN DIAMETER) *

(IT IS USED FOR THE WATERING OF PLANTS AND RELEASES WATER
WHEN THE PRODUCT COMES IN CONTACT WITH SOIL
(MICROBIOLOGICAL ENVIRONMENT))

3824.90



- Preparation put up for retail sale in plastic bottle. Presented in the form of a opaque viscous scented liquid , containing a quaternary surfactant agent (ammonium triethanol dialkyl ester methosulfate , acrylamide polymer & ammonium acrylate) . 4% fragrance , mineral oil , polymer, trialkyl amin phosphonic acid (adjuvant), lactic acid (reinforcing) colourant & water (95 %) . It is used to prevent static cling & make clothes softer . It is added to a load of laundry on the final rinse. - 3809.91

**AGRICULTURAL PRODUCT INTENDED FOR THE CORRECTIONS OF
MICRONUTRIENT SHORTAGES IN SOIL, PRESENTED IN THE FORM OF A GREEN POWDER
COMPLETELY SOLUBLE IN WATER * (IT IS A CHEMICAL COMPOUND WITH A MIXTURE OF
MAGNESIUM OXIDE (9 %), SULPHUR (3 %), IRON (4 %), ZINC (1.5 %), COPPER (1.5 %),
BORON (0.5 %) AND MOLYBDENUM (0.1 %) / THESE CATIONS ARE CHELATED WITH
'EDTA') (IT IS PRESENTED IN PLASTIC BAGS CONTAINING 250 G)**

3824.90 { Ethylenediaminetetraacetic acid (EDTA)

**NICOTINE CARTRIDGES CONSISTING OF A MOUTHPIECE (INHALER) AND A
LIQUID CONTAINER, INTENDED TO BE USED WITH THE DEVICE REFERRED TO
AS "ELECTRONIC SMOKEY" * (THEY ARE PUT UP IN A PACKAGING
CONTAINING 5 CARTRIDGES)**

3824.90

SECTION VII

PLASTICS AND ARTICLES THEREOF; RUBBER AND ARTICLES THEREOF

Chapter 39

Plastics and articles thereof

Notes.

1. Throughout the Nomenclature the expression “plastics” means those materials of headings 39.01 to 39.14 which are or have been capable, either at the moment of polymerization or at some subsequent stage, of being formed under external influence (usually heat and pressure, if necessary with a solvent or plasticizer) by moulding, casting, extruding, rolling or other process into shapes which are retained on the removal of the external influence. Throughout the Nomenclature any reference to “plastics” also includes vulcanized fibre. The expression, however, does not apply to materials regarded as textile materials of Section XI.

Chapter 39

Plastics and articles thereof

Contd...

2. This Chapter does not cover :
 - (a) Lubricating preparations of heading 27.10 or 34.03;
 - (b) Waxes of heading 27.12 or 34.04;
 - (c) Separate chemically defined organic compounds (Chapter 29);
 - (d) Heparin or its salts (heading 30.01);
 - (e) Solutions (other than collodions) consisting of any of the products specified in headings 39.01 to 39.13 in volatile organic solvents when the weight of the solvent exceeds 50 % of the weight of the solution (heading 32.08); stamping foils of heading 32.12;

- (f) Organic surface-active agents or preparations of heading 34.02;
- (g) Run gums or ester gums (heading 38.06);
- (h) Prepared additives for mineral oils (including gasoline) or for other liquids used for the same purposes as mineral oils (heading 38.11) ;
- (ij) Prepared hydraulic fluids based on polyglycols, silicones or other polymers of Chapter 39 (heading 38.19);
- (k) Diagnostic or laboratory reagents on a backing of plastics (heading 38.22);
- (l) Synthetic rubber, as defined for the purposes of Chapter 40, or articles thereof;
- (m) Saddlery or harness (heading 42.01) or trunks, suitcases, handbags or other containers of heading 42.02;
- (n) Plaits, wickerwork or other articles of Chapter 46;
- (o) Wall coverings of heading 48.14;
- (p) Goods of Section XI (textiles and textile articles);
- (q) Articles of Section XII (for example, footwear, headgear, umbrellas, sun umbrellas, walking-sticks, whips, riding-crops or parts thereof);

- (r) Imitation jewellery of heading 71.17;
- (s) Articles of Section XVI (machines and mechanical or electrical appliances);
- (t) Parts of aircraft or vehicles of Section XVII;
- (u) Articles of Chapter 90 (for example, optical elements, spectacle frames, drawing instruments);
- (v) Articles of Chapter 91 (for example, clock or watch cases);
- (w) Articles of Chapter 92 (for example, musical instruments or parts thereof);
- (x) Articles of Chapter 94 (for example, furniture, lamps and lighting fittings, illuminated signs, prefabricated buildings);
- (y) Articles of Chapter 95 (for example, toys, games, sports requisites); or
- (z) Articles of Chapter 96 (for example, brushes, buttons, slide fasteners, combs, mouthpieces or stems for smoking pipes, cigarette-holders or the like, parts of vacuum flasks or the like, pens, propelling pencils).

39.23		Articles for the conveyance or packing of goods, of plastics; stoppers, lids, caps and other closures, of plastics.
	3923.10	- Boxes, cases, crates and similar articles :
	3923.10.10	--- Containers imported for the packing of gems and jewellery
	3923.10.20	--- Plastic cages for the transport of live poultry
	3923.10.30	--- Plastic crates of a kind used for the transport of fruits and vegetables
	3923.10.90	--- Other
		- Sacks and bags (including cones) :
	3923.21	-- Of polymers of ethylene :
	3923.21.10	--- Made of sheeting with thickness of 40 microns and below
	3923.21.20	--- Other, heat shrinkable bags, printed for packing of poultry products
	3923.21.90	--- Other
	3923.29	-- Of other plastics :
	3923.29.10	--- Made of sheeting with thickness of 40 microns and below
	3923.29.20	--- Other, heat shrinkable bags, printed for packing of poultry products
	3923.29.90	--- Other
	3923.30	- Carboys, bottles, flasks and similar articles
	3923.30.10	--- Bottles of a capacity not exceeding 300 ml
	3923.30.90	--- Other
	3923.40	- Spools, cops, bobbins and similar supports
	3923.50	- Stoppers, lids, caps and other closures :
	3923.50.10	--- Pre-formed shrink capsules
	3923.50.90	--- Other
	3923.90	- Other

Tubular Containers with Plastic cap

Tubular Containers with Plastic cap. made of plastic. of different lengths , diameters , colours, & capacities with one open end threaded & secured with a screw type cap& the other end open but intended to be sealed with clamps, using a thermal process , after the containers are filled with the intended products. They are commonly used for packing cosmetic preparations for retail sale. Their outer surface presents printed information about the products with which they will be filled , such as brand name etc.. 3923.90

PRODUCT DESCRIPTION : BUCKETS OF PLASTICS (HIGH DENSITY POLYETHYLENE) WITH LID AND HANDLE

(CAPACITIES OF 4 L OR 20 L)

- Subheading 3923.30 covers “Carboys, bottles, flasks and similar articles”. The Explanatory Note to heading 70.10 distinguishes, however, between carboys and bottles on the one hand, and jars and pots, on the other hand. The latter are described as “generally having a large opening” (*Explanatory Note to heading 70.10, first paragraph Item (B), second subparagraph, on page 1018*).

In addition, the Concise Oxford Dictionary describes a bottle and a flask as a “narrow necked vessel” and a “narrow-necked bottle”, respectively

3923.90



TRADE MARK : JACKNOBBER II

PRODUCT DESCRIPTION : **HAND MASSAGE TOOL**, MADE FROM ACRYLIC RESIN, IN THE FORM OF FOUR KNOBBED LEGS (TWO SMALL KNOBS AND TWO LARGE ONES) EXTENDING AWAY FROM EACH OTHER)

***(WEIGHT : 67 GR / DIMENSIONS : 11 CM WIDE, 11 CM LONG AND 9 CM HIGH)**

3926.90



INDEXED BUSINESS CARD HOLDER, OF PLASTICS * (4-RING BINDER CONSISTING OF TWO PIECES OF PAPERBOARD BACKING COVERED BY PLASTIC SHEETING, THE OUTER SURFACE OF WHICH HAS BEEN GRAINED TO IMITATE LEATHER, AND JACKETS OF TRANSPARENT PLASTIC MATERIAL FOR INDEXING BUSINESS CARDS FROM "A" TO "Z" / A THIN LAYER OF PADDING MATERIAL OF CELLULAR PLASTIC HAS ALSO BEEN INCORPORATED ON THE OUTER SIDES BETWEEN THE PAPERBOARD BACKING AND THE PLASTIC SHEETING) * (SIZE : APPROXIMATELY 12cmX25cm)

3926.90



40. Rubber and articles thereof.

Chapter 40

Rubber and articles thereof

Notes.

1. Except where the context otherwise requires, throughout the Nomenclature the expression "rubber" means the following products, whether or not vulcanized or hard : natural rubber, balata, gutta-percha, guayule, chicle and similar natural gums, synthetic rubber, factice derived from oils, and such substances reclaimed.

2. This Chapter does not cover :
 - a) Goods of Section XI (textiles and textile articles);
 - b) Footwear or parts thereof of Chapter 64;
 - c) Headgear or parts thereof (including bathing caps) of Chapter 65;
 - d) Mechanical or electrical appliances or parts thereof of Section XVI (including electrical goods of all kinds), of hard rubber;
 - e) Articles of Chapter 90, 92, 94 or 96; or
 - f) Articles of Chapter 95 (other than sports gloves, mittens and mitts and articles of headings 40.11 to 40.13).

Graduated dropper tubes

- **Made up of two different components** fitted together for supplying products such as liquid pharmaceuticals in measured doses .Such tubes comprised of the following :
 - tubular dosage measure of **transparent plastic** material with a graduated scale from 0.25 to 1.0 ml . It is 5.8 c m long , has different diameters at each end and weighs 1.1 gr and
 - Cylindrical teat of **vulcanized rubber** weighing 2.4 g r .
- 4016.99.90
- GRI ?

SECTION VIII

RAW HIDES AND SKINS, LEATHER, FURSKINS AND ARTICLES THEREOF; SADDLERY AND HARNESS; TRAVEL GOODS, HANDBAGS AND SIMILAR CONTAINERS; ARTICLES OF ANIMAL GUT (OTHER THAN SILK-WORM GUT)

41. Raw hides and skins (other than fur skins) and leather.
42. Articles of leather; saddlery and harness; travel goods, handbags and similar containers; articles of animal gut (other than silk- worm gut)

Chapter 42

Articles of leather; saddlery and harness; travel goods, handbags and similar containers; articles of animal gut (other than silk-worm gut)

Notes.

1.- This Chapter does not cover :

- (a) Sterile surgical catgut or similar sterile suture materials (heading 30.06);
- (b) Articles of apparel or clothing accessories (except gloves, mittens and mitts), lined with furskin or artificial fur or to which furskin or artificial fur is attached on the outside except as mere trimming (heading 43.03 or 43.04);
- (c) Made up articles of netting (heading 56.08);
- (d) Articles of Chapter 64;
- (e) Headgear or parts thereof of Chapter 65;

- (f) Whips, riding-crops or other articles of heading 66.02;
- (g) Cuff-links, bracelets or other imitation Jewellery (heading 71.17);
- (h) Fittings or trimmings for harness, such as stirrups, bits, horse brasses and buckles, separately presented (generally Section XV);
- (ij) Strings, skins for drums or the like, or other parts of musical instruments (heading 92.09);
- (k) Articles of Chapter 94 (for example, furniture, lamps and lighting fittings);
- (l) Articles of Chapter 95 (for example, toys, games, sports requisites); or
- (m) Buttons, press-fasteners, snap-fasteners, press-studs, button moulds or other parts of these articles, button blanks, of heading 96.06.

2.

In addition to the provisions of Note 1 above, heading 42.02 does not cover :

- a) Bags made of sheeting of plastics, whether or not printed, with handles, not designed for prolonged use (heading 39.23);
- b) Articles of plaiting materials (heading 46.02).

Articles of headings 42.02 and 42.03 which have parts of precious metal or metal clad with precious metal, of natural or cultured pearls, of precious or semi-precious stones (natural, synthetic or reconstructed) remain classified in those headings even if such parts constitute more than minor fittings or minor ornamentation, provided that these parts do not give the articles their essential character. If, on the other hand, the parts give the articles their essential character, the articles are to be classified in Chapter 71.

43. Fur skins and artificial fur; manufactures thereof.

SECTION IX
**WOOD AND ARTICLES OF WOOD; WOOD CHARCOAL;
CORK AND ARTICLES OF CORK; MANUFACTURES OF STRAW,
OF ESPARTO OR OF OTHER PLAITING MATERIALS;
BASKETWARE AND WICKERWORK**

44. Wood and articles of wood; wood charcoal.

Chapter 44
Wood and articles of wood; wood charcoal

Notes.

1. This Chapter does not cover :
 - (a) Wood, in chips, in shavings, crushed, ground or powdered, of a kind used primarily in perfumery, in pharmacy, or for insecticidal, fungicidal or similar purposes (heading 12.11);

- (b) Bamboos or other materials of a woody nature of a kind used primarily for plaiting, in the rough, whether or not split, sawn lengthwise or cut to length (heading 14.01);
- (c) Wood, in chips, in shavings, ground or powdered, of a kind used primarily in dyeing or in tanning (heading 14.04);
- (d) Activated charcoal (heading 38.02);
- (e) Articles of heading 42.02;
- (f) Goods of Chapter 46;
- (g) Footwear or parts thereof of Chapter 64;
- (h) Goods of Chapter 66 (for example, umbrellas and walking-sticks and parts thereof);
- (ij) Goods of heading 68.08;
- (k) Imitation jewellery of heading 71.17;

- (l) Goods of Section XVI or Section XVII (for example, machine parts, cases, covers, cabinets for machines and apparatus and wheelwrights' wares);
- (m) Goods of Section XVIII (for example, clock cases and musical instruments and parts thereof);
- (n) Parts of firearms (heading 93.05);
- (o) Articles of Chapter 94 (for example, furniture, lamps and lighting fittings, prefabricated buildings);
- (p) Articles of Chapter 95 (for example, toys, games, sports requisites);
- (q) Articles of Chapter 96 (for example, smoking pipes and parts thereof, buttons, pencils) excluding bodies and handles, of wood, for articles of heading 96.03; or
- (r) Articles of Chapter 97 (for example, works of art).

45. Cork and articles of cork.

46. Manufactures of straw, of esparto or of other plaiting materials; basket ware and wickerwork.

SECTION X

PULP OF WOOD OR OF OTHER FIBROUS CELLULOSIC MATERIAL; RECOVERED (WASTE AND SCRAP) PAPER OR PAPERBOARD; PAPER AND PAPERBOARD AND ARTICLES THEREOF

47. Pulp of wood or of other fibrous cellulosic material; recovered (waste and scrap) paper or paperboard.

48 Paper and paperboard; articles of paper pulp, of paper or of paperboard .

49. . Printed books, newspapers, pictures and other products of the printing industry; manuscripts, typescripts and plans.

Section X

PULP OF WOOD OR OF OTHER FIBROUS CELLULOSIC MATERIAL; RECOVERED (WASTE AND SCRAP) PAPER OR PAPERBOARD; PAPER AND PAPERBOARD AND ARTICLES THEREOF

The most important pulp in international trade is wood pulp termed **Mechanical wood pulp, Chemical wood pulp, Semi chemical wood pulp or Chemi- mechanical pulp**. The wood mostly used are Pine, Spruce , Poplar, & Aspin. (but hard wood are also used .)

Other Material used for making Pulp.

Cotton linters (14.04)

Recovered (waste & scrap)paper or paper board . (47.07)

Rags (particularly cotton ,linen or hemp)& other textile waste. (63.10)

Straw ,esparto, flax, ramie, jute, hemp. Sisal, bagasse, bamboo & various other grasses & reeds.

47.07 Recovered (waste and scrap) paper or paperboard (+).

Waste of paper or paperboard covered by this heading includes shavings, cuttings, clippings , torn sheets, old news papers & journals, proof sheets, printers rejects and similar materials.

The heading also covers scrap articles of paper & paperboard.

Such waste & scrap is normally used for pulping & is often presented in compressed bales, but it should be noted that it is possible use for other purpose(e.g. , packing) does not exclude its classification in this heading.

Waste & scrap photographic paper & paperboard containing Silver or compounds thereof – heading 71.12

Chapter 48

Paper and paperboard; articles of paper pulp, of paper or of paperboard

- .-2..... This Chapter does not cover :
-
- (a) Articles of Chapter 30;
- (b) Stamping foils of heading 32.12; ...
- (c) Perfumed papers or papers impregnated or coated with cosmetics (Chapter 33);
- (d) Paper or cellulose wadding impregnated, coated or covered with soap or detergent (heading 34.01), or with polishes, creams or similar preparations (heading 34.05);
- (e) Sensitized paper or paperboard of headings 37.01 to 37.04;
- (f) Paper impregnated with diagnostic or laboratory reagents (heading 38.22);
- (g) Paper-reinforced stratified sheeting of plastics, or one layer of paper or paperboard coated or covered with a layer of plastics, the latter constituting more than half the total thickness, or articles of such materials, other than wall coverings of heading 48.14 (Chapter 39);

Note 2

- h) Articles of heading 42.02 (for example, travel goods);
- (ij) Articles of Chapter 46 (manufactures of plaiting material);
- (k) Paper yarn or textile articles of paper yarn (Section XI);
- (l) Articles of Chapter 64 or Chapter 65;
- (m) Abrasive paper or paperboard (heading 68.05) or paper- or paperboard-backed mica (heading 68.14) (paper and paperboard coated with mica powder are, however, to be classified in this Chapter);
- (n) Metal foil backed with paper or paperboard (generally Section XIV or XV);
- (o) Articles of heading 92.09; or
- (p) Articles of Chapter 95 (for example, toys, games, sports requisites) or
- (q) articles of chapter 96 (Eg. Buttons ,sanitary towels (pads) &tampons, napkins (diapers) & napkin liners for babies.

Chapter note 6

- In this Chapter "kraft paper and paperboard" means paper and paperboard of which not less than 80% by weight of the total fibre content consists of fibres obtained by the chemical sulphate or soda processes.

Note 08.

- Headings 48.01 and 48.03 to 48.09 apply only to paper, paperboard, cellulose wadding and webs of cellulose fibres :
- (a) in strips or rolls of a width exceeding 36 cm; or
- (b) in rectangular (including square) sheets with one side exceeding 36 cm and the other side exceeding 15 cm in the unfolded state.

Subheading note

- 1.- For the purposes of subheadings 4804.11 and 4804.19, "kraftliner" means machine-finished or machine-glazed paper and paperboard, of which not less than 80% by weight of the total fibre content consists of wood fibres obtained by the chemical sulphate or soda processes, in rolls, weighing more than 115 g/m² and having a minimum Mullen bursting strength as indicated in the following table or the linearly interpolated or extrapolated equivalent for any other weight.

Weight strength <u>g/m²</u>	Minimum Mullen bursting <u>kPa</u>
• 115	393
• 125	417
• 200	637
• 300	824
• 400	961

Note 02

- For the purposes of subheadings 4804.21 and 4804.29, "sack Kraft paper" means machine-finished paper, of which not less than 80 % by weight of the total fibre content consists of fibres obtained by the chemical sulphate or soda processes, in rolls, weighing not less than 60 g/m² but not more than 115 g/m² and meeting one of the following sets of specifications :
 -
 - (a) Having a Mullen burst index of not less than 3.7 kPa·m²/g and a stretch factor of more than 4.5% in the cross direction and of more than 2% in the machine direction.
 -
 - (b) Having minima for tear and tensile as indicated in the following table or the linearly interpolated equivalent for any other weight :

48.08 Paper and paperboard, corrugated (with or without glued flat surface sheets), creped, crinkled, embossed or perforated, in rolls or sheets, other than paper of the kind described in heading 48.03.

48.10 Paper and paperboard, coated on one or both sides with kaolin (China clay) or other inorganic substances, with or without a binder, and with no other coating, whether or not surface-coloured, surface-decorated or printed, in rolls or rectangular (including square) sheets, of any size (+).

48.11 Paper, paperboard, cellulose wadding and webs of cellulose fibres, coated, impregnated, covered, surface-coloured, surface, decorated or printed, in rolls or rectangular (including square) sheets, of any size, other than goods of the kind described in heading 48.03, 48.09 or 48.10 .

4811.59.20 --- Printed wrappers for wrapping of soap

4811.41.20 --- Printed wrappers for wrapping of soap

4911.90.10 --- Printed wrappers for wrapping of soap

(refer note (D) to chapter 48.11 page X-4811-1 . & note 12 to chapter 48 . Page X- 48-3 ,..... printed with motifs, characters or pictorial representations, which are not merely incidental to the primary use of the goods, fall in Chapter 49.)

4811.90.20 --- Kraft paper and paperboard, laminated with aluminium foil, in rolls or reels of a width exceeding 75 cm

(7607.20.20 ---Aluminium foil backed with Kraft paper or Kraft paperboard, in rolls or reels of a width exceeding 75 cm.)

48.12 Filter blocks, slabs and plates, of paper pulp

Filter blocks are used in clarifying liquids (eg. Wine, sprits ..) They are classified in this heading irrespective of their size or shape. Other paper products used for filtering liquids e.g. Filter paper 48.05 or 48.23 , Cellulose wadding 48.03 or 48.23 .

48.13 Cigarette paper, whether or not cut to size or in the form of booklets or tubes.

48.14 Wallpaper and similar wall coverings; window transparencies of paper (+).

48.16 Carbon paper, self-copy paper and other copying or transfer papers (other than those of heading 48.09), duplicator stencils and offset plates, of paper, whether or not put up in boxes

Section XI Textile and textile articles.

This section does not cover.

- 1 (g) Mono filament of which any cross sectional dimension exceed 1mm or strip or the like (e.g artificial straw) of an apparent width exceeding 5mm of plastic (chapter 39).....
- (h) woven, knitted or crocheted fabric ,felt or nonwovens ,impregnated , coated covered or laminated with plastic or articles thereof , of chapter 39. **(Refer plastic &textile combination page vii-39-12)**
- (ij) woven, knitted or crocheted fabric ,felt or nonwovens ,impregnated , coated covered or laminated with rubber or articles thereof , of chapter 49 . **(Refer rubber &textile combination page vii-40-5)**
- (l)Articles of textile materials of heading 42.01 or 4202.
- (n) footwear or parts of footwear , gaiters or leggings ...**(bootees without an outer sole glued ,sewn or otherwise affixed or applied to the upper 61.11)**
- (o) hair nets or other head gear or parts thereof .
- (q) Abrasive coated fabric (68.05) , .. Carbon fibres or articles of carbon fibre of heading 68.15

Note 3- (A) to section XI. For the purpose for this section ... **(distinction between single, multiple (folded) or cabled yarn of chapter 50 to 55, twine cordage , rope or cables of 56.07) & braids of heading 58.08)**

Note 5. For the purpose of heading 52.04, 54.01, & 55.08 the expression sewing thread means multiple (folded) or cable yarn :

- (a) put up on support (for eg , reels , tubes) of a weight (including support) not exceeding 1,000 gr;
- (b) Dressed for use as sewing thread and
- (c) with a final “Z” twist .

Direction

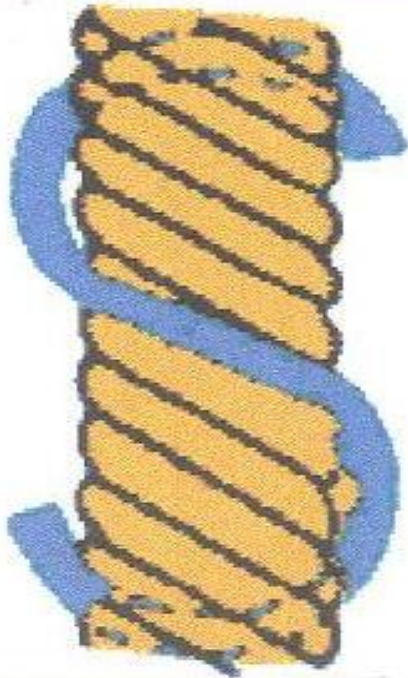

Right twist
(S twist)



Left twist
(Z twist)

Made up articles. (Not 7 to section XI)

- Merely cut , otherwise than into square or rectangles. (e.g dress patterns of textile materials;
- Produced in the finished state, ready for use.
- Cut to size & with at least one heat sealed edge.
- Hemmed or with rolled edge or with a knotted fringe.
- Cut to size and incorporating drawn thread work.
- Assembled by sewing. Gumming or otherwise.
- Knitted or crocheted to shape.
- (Refer page XI-18)

Chapter 50 Silk

Chapter 51 Wool, fine or coarse animal hair; horsehair yarn and woven fabric

Note.

1.- Throughout the Nomenclature :

- (a) "Wool" means the natural fibre grown by sheep or lambs;
- (b) "Fine animal hair" means the hair of alpaca, llama, vicuna, camel (including dromedary), yak, Angora, Tibetan, Kashmir or similar goats (but not common goats), rabbit (including Angora rabbit), hare, beaver, nutria or musk-rat;
- (c) "Coarse animal hair" means the hair of animals not mentioned above, excluding brush-making hair and bristles (heading 05.02) and horsehair (heading 05.11).

Chapter 52. Cotton.

- Chapter 53. **Other Vegetable textile fibres; Paper yarn and woven fabric of paper yarn**

Chapter 54. Man-made filaments; strip and the like of man-made textile materials

synthetic fibres , (note 1 chapter 54 - acrylic ,modacrylic, nylon or other polyamids, polyestr , polyethylene, polyurathene) .

Artificial fibres, (note ii chapter 54 - viscose rayon, cupramonium rayon ,cellulose asetate, protein fibres, aliginate fibres.)

54.04 Synthetic monofilament of 67 decitex or more and of which no cross-sectional dimension exceeds 1 mm; strip and the like (for example, artificial straw) of synthetic textile materials of an apparent width not exceeding 5 mm. (refer note (1) &(2) to heading 54.04 - page xi-5404-1

54.05 Artificial monofilament of 67 decitex or more and of which no cross-sectional dimension exceeds 1 mm; strip and the like (for example, artificial straw) of artificial textile materials of an apparent width not exceeding 5 mm.

54.07 Woven fabrics of synthetic filament yarn, including woven fabrics obtained from materials of heading 54.04.

54.08 Woven fabrics of artificial filament yarn, including woven fabrics obtained from materials of heading 54.05.

Chapter 55 Man- made staple fibres . (fibres usually between 25 mm &180 mm and varies according to the particular man made fibre).

- Chapter 56, **Wadding, felt and nonwovens; special yarns; twine, cordage, ropes and cables and articles thereof**
- **Notes.**
- 1.- This Chapter does not cover :
- Wadding, felt or nonwovens, impregnated, coated or covered with substances or preparations (for example, perfumes or cosmetics of Chapter 33, soaps or detergents of heading 34.01, polishes, creams or similar preparations of heading 34.05, fabric softeners of heading 38.09) where the textile material is present merely as a carrying medium;
- Textile products of heading 58.11;
- Natural or artificial abrasive powder or grain, on a backing of felt or nonwovens (heading 68.05);
- Agglomerated or reconstituted mica, on a backing of felt or nonwovens (heading 68.14); or
- Metal foil on a backing of felt or nonwovens (generally Section XIV or XV).
- Sanitary towels (pads) & tampons , napkins (diapers) & napkin liners for babies & similar articles of heading 96.19.

56.07 Twine, cordage, ropes and cables, whether or not plaited or braided and whether or not impregnated, coated, covered or sheathed with rubber or plastics (+).

(g) abrasive coated twine , cord ,etc heading 68.05 page XI-5607-2

56.08 Knotted netting of twine, cordage or rope; made up fishing nets and other made up nets, of textile materials.

made up nets of this are restricted to those not covered more specifically by other headings. The heading includes fishing nets, camouflage nets, theatrical scenery nets, safety nets, net shopping bags & similar carrying nets, (for tennis balls or foot balls), hammocks, balloon or air-ship nets, nets for protecting against insects, etc.

5609.00 Articles of yarn, strip or the like of heading 54.04 or 54.05, twine, cordage, rope or cables, not elsewhere specified or included

(It include yarns, cordage, rope , etc., cut to length & looped at one or both ends or fitted with tags , hooks ,etc., (e.g., shoe laces , clothes lines, towing ropes), rope ladders ,ship's fenders, unloading cushions, loading slings, etc.)

(c) Shoe laces made from braids are classified in heading 63.07

3.- (A) For the purposes of this Section, and subject to the exceptions in paragraph (B) below, yarns (single, multiple (folded) or cabled) of the following descriptions are to be treated as "twine, cordage, ropes and cables" :

- (a) Of silk or waste silk, measuring more than 20,000 decitex;**
- (b) Of man-made fibres (including yarn of two or more monofilaments of Chapter 54), measuring more than 10,000 decitex;**
- (c) Of true hemp or flax :**
 - (i) Polished or glazed, measuring 1,429 decitex or more; or**
 - (ii) Not polished or glazed, measuring more than 20,000 decitex;**
- (d) Of coir, consisting of three or more plies;**
- (e) Of other vegetable fibres, measuring more than 20,000 decitex;**

Classification of yarns, twine, cordage, rope and cables of textile material.

Type (*)	Characteristics determining classification	Classification
Reinforced with metal thread	In all cases	Heading 56.07
Of metallised yarn	In all cases	Heading 56.05
Gimped yarn, other than those of headings 51.10 and 56.05, chenille yarn and loop wale yarn	In all cases	Heading 56.06
Braided textile yarn	(1) Tightly plaited and with a compact structure	Heading 56.07
	(2) Other	Heading 58.08
Other : - Of silk or waste silk (**)	(1) Measuring 20,000 decitex or less	Chapter 50
	(2) Measuring more than 20,000 decitex	Heading 56.07
- Of wool or other animal hair	In all cases	Chapter 51
- Of flax or true hemp	(1) Polished or glazed :	
	(a) Measuring 1,429 decitex or more	Heading 56.07
	(b) Measuring less than 1,429 decitex	Chapter 53
	(2) Neither polished nor glazed :	
(a) Measuring 20,000 decitex or less	Chapter 53	
(b) Measuring more than 20,000 decitex	Heading 56.07	
- Of coir	(1) Of one or two plies	Heading 53.08
	(2) Of three or more plies	Heading 56.07
- Of paper	In all cases	Heading 53.08
- Of cotton or other vegetable fibres	(1) Measuring 20,000 decitex or less	Chapter 52 or 53
	(2) Measuring more than 20,000 decitex	Heading 56.07
- Of man-made fibres (including those yarns of two or more monofilaments of Chapter 54 (**))	(1) Measuring 10,000 decitex or less	Chapter 54 or 55
	(2) Measuring more than 10,000 decitex	Heading 56.07

Chapter 57 Carpets and other textile floor coverings

Chapter 58 Special woven fabrics; tufted textile fabrics; lace; tapestries; trimmings; embroidery

58.04 Tullies and other net fabrics, not including woven, knitted or crocheted fabrics; lace in the piece, in strips or in motifs, other than fabrics of heading 60.02 to 60.06.

58.10 Embroidery in the piece, in strips or in motifs (+).

•

•

Chapter 59

Impregnated, coated, covered or laminated textile fabrics; textile articles of a kind suitable for industrial use

Heading 59.03 applies to :

- (a) Textile fabrics, impregnated, coated, covered or laminated with plastics, whatever the weight per square metre and whatever the nature of the plastic material (compact or cellular), other than :**
 - (1) Fabrics in which the impregnation, coating or covering cannot be seen with the naked eye (usually Chapters 50 to 55, 58 or 60); for the purpose of this provision, no account should be taken of any resulting change of colour;**
 - (2) Products which cannot, without fracturing, be bent manually around a cylinder of a diameter of 7 mm, at a temperature between 15 °C and 30 °C (usually Chapter 39);**
 - (3) Products in which the textile fabric is either completely embedded in plastics or entirely coated or covered on both sides with such material, provided that such coating or covering can be seen with the naked eye with no account being taken of any resulting change of colour (Chapter 39);**
 - (4) Fabrics partially coated or partially covered with plastics and bearing designs resulting from these treatments (usually Chapters 50 to 55, 58 or 60);**
 - (5) Plates, sheets or strip of cellular plastics, combined with textile fabric, where the textile fabric is present merely for reinforcing purposes (Chapter 39); or**
 - (6) Textile products of heading 58.11;**

60. Knitted or crocheted fabrics.

61. Articles of apparel and clothing accessories knitted or crocheted.

Chapter 61

Articles of apparel and clothing accessories, knitted or crocheted

3. For the purposes of headings 61.03 and 61.04 :

- (a) The term "suit" means a set of garments composed of two or three pieces made up, in respect of their outer surface, in identical fabric and comprising :
- one suit coat or jacket the outer shell of which, exclusive of sleeves, consists of four or more panels, designed to cover the upper part of the body, possibly with a tailored waistcoat in addition whose front is made from the same fabric as the outer surface of the other components of the set and whose back is made from the same fabric as the lining of the suit coat or jacket; and
 - one garment designed to cover the lower part of the body and consisting of trousers, breeches or shorts (other than swimwear), a skirt or a divided skirt, having neither braces nor bibs.

All of the components of a "suit" must be of the same fabric construction, colour and composition; they must also be of the same style and of corresponding or compatible size. However, these components may have piping (a strip of fabric sewn into the seam) in a different fabric.

If several separate components to cover the lower part of the body are presented together (for example, two pairs of trousers or trousers and shorts, or a skirt or divided skirt and trousers), the constituent lower part shall be one pair of trousers or, in the case of women's or girls' suits, the skirt or divided skirt, the other garments being considered separately.

The term "suit" includes the following sets of garments, whether or not they fulfill all the below conditions :

- morning dress, comprising a plain jacket (cutaway) with rounded tails hanging well down at the back and striped trousers;
- evening dress (tailcoat), generally made of black fabric, the jacket of which is relatively short at the front, does not close and has narrow skirts cut in at the hips and hanging down behind;
- dinner jacket suits, in which the jacket is similar in style to an ordinary jacket (though perhaps revealing more of the shirt front), but has shiny silk or imitation silk lapels.

- (b) The term "ensemble" means a set of garments (other than suits and articles of heading 61.07, 61.08 or 61.09), composed of several pieces made up in identical fabric, put up for retail sale, and comprising :
- one garment designed to cover the upper part of the body, with the exception of pullovers which may form a second upper garment in the sole context of twin sets, and of waistcoats which may also form a second upper garment, and;
 - one or two different garments, designed to cover the lower part of the body and consisting of trousers, bib and brace overalls, breeches, shorts (other than swimwear), a skirt or a divided skirt.

All of the components of an ensemble must be of the same fabric construction, style, colour and composition; they also must be of corresponding or compatible size. The term "ensemble" does not apply to track suits or ski suits, of heading 61.12.

6. For the purposes of heading 61.11 :
- a) The expression "babies' garments and clothing accessories" means articles for young children of a body height not exceeding 86 cm; it also covers babies' napkins;
 - b) Articles which are, *prima facie*, classifiable both in heading 61.11 and in other headings of this Chapter are to be classified in heading 61.11.
9. Garments of this Chapter designed for left over right closure at the front shall be regarded as men's or boys' garments, and those designed for right over left closure at the front as women's or girls' garments. These provisions do not apply where the cut of the garment clearly indicates that it is designed for one or other of the sexes.

Garments which cannot be identified as either men's or boys' garments or as women's or girls' garments are to be classified in the headings covering women's or girls' garments.



The term “ T-shirts ” means lightweight knitted or crocheted garments of the vest type, of cotton or man-made fibre, not napped, nor of pile or terry fabric, in one or more colours, with or without pockets, with long or short close-fitting sleeves, without buttons or other fastenings, without collar, without opening in the neckline, having a close-fitting or lower neckline (round, square, boat-shaped or V-shaped). These garments may have decoration, other than lace, in the form of advertising, pictures or an inscription in words, obtained by printing, knitting or other process. The bottom of these garments is usually hemmed.

62. Articles of apparel and clothing accessories not knitted or crocheted.

63. Other made up textile articles; sets; worn clothing and worn textile articles; rags.

Lumber support belt.

- Elasticised woven fabric with a crosswise structure ensuring stability of the belt (preventing it forming creasing) and “ Velcro fastener . In the back of the belt.
- This belt is in different sizes according to the patients waist measurements .
- It is described as being used for **prevention & treatment** of
- Back pain, or for post – operative support . Etc...

6212.90

Note 1 b to chapter 90 excludes) –(b) Supporting belts or other support articles of textile material, whose intended effect on the organ to be supported or held derives solely from their elasticity (for example, **maternity belts, thoracic support bandages, abdominal support bandages, supports for joints or muscles**) section XI

SECTION XII

FOOTWEAR, HEADGEAR, UMBRELLAS, SUN UMBRELLAS, WALKING-STICKS, SEAT-STICKS, WHIPS, RIDING-CROPS AND PARTS THEREOF; PREPARED FEATHERS AND ARTICLES MADE THEREWITH; ARTIFICIAL FLOWERS; ARTICLES OF HUMAN HAIR

64. Footwear, gaiters and the like; parts of such articles.
65. Headgear and parts thereof.
66. Umbrellas, sun umbrellas, walking-sticks, seat-sticks, whips, riding-crops and parts thereof.
67. Prepared feathers and down and articles made of feathers or of down; artificial flowers; articles of human hair.

Chapter 67

Prepared feathers and down and articles made of feathers or of down; artificial flowers; articles of human hair

Notes.

1. This Chapter does not cover :

- a) Straining cloth of human hair (heading 59.11);
- b) Floral motifs of lace, of embroidery or other textile fabric (Section XI);
- c) Footwear (Chapter 64);
- d) Headgear or hair-nets (Chapter 65);
- e) Toys, sports requisites or carnival articles (Chapter 95); or
- f) Feather dusters, powder-puffs or hair sieves (Chapter 96).

67.01	6701.00	Skins and other parts of birds with their feathers or down, feathers, parts of feathers, down and articles thereof (other than goods of heading 05.05 and worked quills and scapes).
67.02		Artificial flowers, foliage and fruit and parts thereof; articles made of artificial flowers, foliage or fruit.
	6702.10	- Of plastics
	6702.90	- Of other materials
67.03	6703.00	Human hair, dressed, thinned, bleached or otherwise worked; wool or other animal hair or other textile materials, prepared for use in making wigs or the like.
67.04		Wigs, false beards, eyebrows and eyelashes, switches and the like, of human or animal hair or of textile materials; articles of human hair not elsewhere specified or included.
		- Of synthetic textile materials :
	6704.11	-- Complete wigs
	6704.19	-- Other
	6704.20	- Of human hair

SECTION XIII
**ARTICLES OF STONE, PLASTER, CEMENT, ASBESTOS, MICA
OR SIMILAR MATERIALS; CERAMIC PRODUCTS;
GLASS AND GLASSWARE**

68. Articles of stone, plaster, cement, asbestos, mica or similar materials.

Chapter 68

Articles of stone, plaster, cement, asbestos, mica or similar materials

Notes.

1. This Chapter does not cover :
 - (a) Goods of Chapter 25;
 - (b) Coated, impregnated or covered paper and paperboard of heading 48.10 or 48.11 (for example, paper and paperboard coated with mica powder or graphite, bituminized or asphalted paper and paperboard);
 - (c) Coated, impregnated or covered textile fabric of Chapter 56 or 59 (for example, fabric coated or covered with mica powder, bituminized or asphalted fabric);

- (d) Articles of Chapter 71;
- (e) Tools or parts of tools, of Chapter 82;
- (f) Lithographic stones of heading 84.42;
- (g) Electrical insulators (heading 85.46) or fittings of insulating material of heading 85.47;
- (h) Dental burrs (heading 90.18);
- (ij) Articles of Chapter 91 (for example, clocks and clock cases);
- (k) Articles of Chapter 94 (for example, furniture, lamps and lighting fittings, prefabricated buildings);
- (l) Articles of Chapter 95 (for example, toys, games and sports requisites);
- (m) Articles of heading 96.02, if made of materials specified in Note 2 (b) to Chapter 96, or of heading 96.06 (for example, buttons), 96.09 (for example, slate pencils) or 96.10 (for example, drawing slates); or
- (n) Articles of Chapter 97 (for example, works of art).

68.02		Worked monumental or building stone (except slate) and articles thereof, other than goods of heading 68.01; mosaic cubes and the like, of natural stone (including slate), whether or not on a backing; artificially coloured granules, chippings and powder, of natural stone (including slate).
	6802.10	- Tiles, cubes and similar articles, whether or not rectangular (including squares), the largest surface area of which is capable of being enclosed in a square the side of which is less than 7 cm; artificially coloured granules, chippings and powder
		- Other monumental or building stone and articles thereof, simply cut or sawn, with a flat or even surface :
	6802.21	-- Marble, travertine and alabaster
	6802.23	-- Granite
	6802.29	-- Other stone
		- Other :
	6802.91	-- Marble, travertine and alabaster
	6802.91.10	--- Unpolished marble slabs, merely cut, with epoxy application on one side and glass fibre netting on the other side
	6802.91.90	--- Other
	6802.92	-- Other calcareous stone
	6802.93	-- Granite
	6802.99	-- Other Stone :
	6802.99.10	--- Balls for crushing mills
	6802.99.90	--- Other

PRODUCT DESCRIPTION : **SCRUB SPONGES**
AND SCORING PADS : **COMPOSITE ARTICLE CONSISTING**
OF THE SPONGE ON ONE SIDE WITH THE ABRASIVE PAD
ATTACHED TO IT ON THE REVERSE SIDE

6805.30

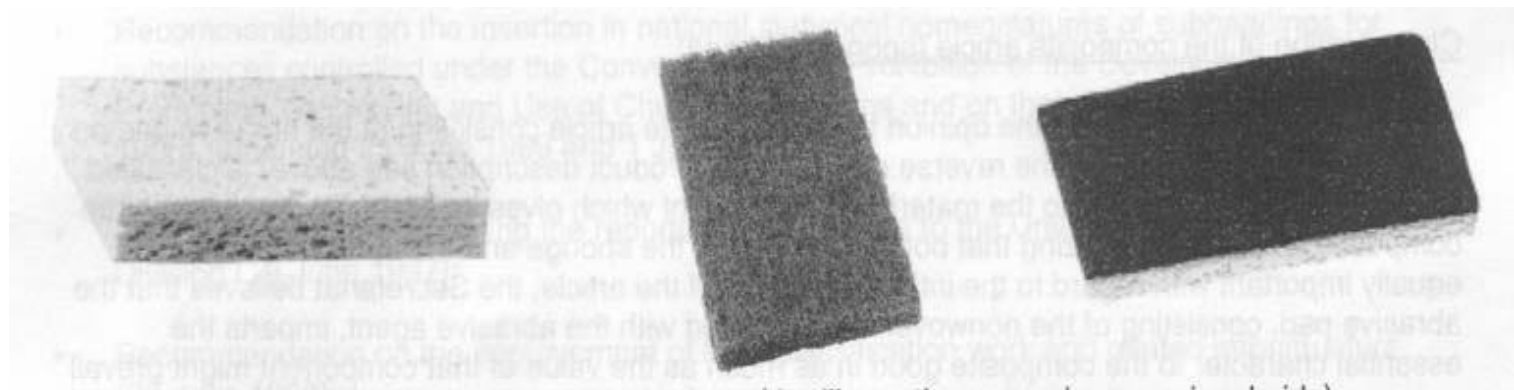

68.05		Natural or artificial abrasive powder or grain, on a base of textile material, of paper, of paperboard or of other materials, whether or not cut to shape or sewn or otherwise made up.
	6805.10	- On a base of woven textile fabric only
	6805.20	- On a base of paper or paperboard only
	6805.30	- On a base of other materials

69. Ceramic products.

70. Glass and glassware.

Chapter 70

Glass and glassware

Notes.

1. This Chapter does not cover :
 - a) Goods of heading 32.07 (for example, verifiable enamels and glazes, glass frit, other glass in the form of powder, granules or flakes);
 - b) Articles of Chapter 71 (for example, imitation jewelery);
 - c) Optical fibre cables of heading 85.44, electrical insulators (heading 85.46) or fittings of insulating material of heading 85.47;
 - d) Optical fibres, optically worked optical elements, hypodermic syringes, artificial eyes, thermometers, barometers, hydrometers or other articles of Chapter 90;
 - e) Lamps or lighting fittings, illuminated signs, illuminated name-plates or the like, having a permanently fixed light source, or parts thereof of heading 94.05;
 - f) Toys, games, sports requisites, Christmas tree ornaments or other articles of Chapter 95 (excluding glass eyes without mechanisms for dolls or for other articles of Chapter 95);
or
 - g) Buttons, fitted vacuum flasks, scent or similar sprays or other articles of Chapter 96.

SECTION XIV

NATURAL OR CULTURED PEARLS, PRECIOUS OR SEMI-PRECIOUS STONES, PRECIOUS METALS, METALS CLAD WITH PRECIOUS METAL AND ARTICLES THEREOF; IMITATION JEWELLERY; COIN

71. Natural or cultured pearls, precious or semi-precious stones, precious metals, metals clad with precious metal and articles thereof; imitation jewellery; coin.

71.17		Imitation Jewellery.
		- Of base metal, whether or not plated with precious metal :
	7117.11	-- Cuff-links and studs
	7117.19	-- Other
	7117.90	- Other

Beaded Necklaces



SECTION XV

BASE METALS AND ARTICLES OF BASE METAL

Section notes

1.- This Section does not cover :

- (a) Prepared paints, inks or other products with a basis of metallic flakes or powder (headings 32.07 to 32.10, 32.12, 32.13 or 32.15);
- (b) Ferro-cerium or other pyrophoric alloys (heading 36.06);
- (c) Headgear or parts thereof of heading 65.06 or 65.07;
- (d) Umbrella frames or other articles of heading 66.03;
- (e) Goods of Chapter 71 (for example, precious metal alloys, base metal clad with precious metal, imitation jewellery);
- (f) Articles of Section XVI (machinery, mechanical appliances and electrical goods);
- (g) Assembled railway or tramway track (heading 86.08) or other articles of Section XVII (vehicles, ships and boats, aircraft);
- (h) Instruments or apparatus of Section XVIII, including clock or watch springs;
- (ij) Lead shot prepared for ammunition (heading 93.06) or other articles of Section XIX (arms and ammunition);
- (k) Articles of Chapter 94 (for example, furniture, mattress supports, lamps and lighting fittings, illuminated signs, prefabricated buildings);
- (l) Articles of Chapter 95 (for example, toys, games, sports requisites);
- (m) Hand sieves, buttons, pens, pencil-holders, pen nibs or other articles Chapter 96 (miscellaneous manufactured articles); or
- (n) Articles of Chapter 97 (for example, works of art).

2.- Throughout the Nomenclature, the expression “ parts of general use ” means :

- (a) Articles of heading 73.07, 73.12, 73.15, 73.17 or 73.18 and similar articles of other base metals;
- (b) Springs and leaves for springs, of base metal, other than clock or watch springs (heading 91.14); and
- (c) Articles of headings 83.01, 83.02, 83.08, 83.10 and frames and mirrors, of base metal, of heading 83.06.

3.-Throughout the Nomenclature, the expression “ base metals ” means : iron and steel, copper, nickel, aluminium, lead, zinc, tin, tungsten (wolfram), molybdenum, tantalum, magnesium, cobalt, bismuth, cadmium, titanium, zirconium, antimony, manganese, beryllium, chromium, germanium, vanadium, gallium, hafnium, indium, niobium (columbium), rhenium and thallium.

5.-Classification of alloys (other than ferro-alloys and master alloys as defined in Chapters 72 and 74) :

- (a) An alloy of base metals is to be classified as an alloy of the metal which predominates by weight over each of the other metals;
- (b) An alloy composed of base metals of this Section and of elements not falling within this Section is to be treated as an alloy of base metals of this Section if the total weight of such metals equals or exceeds the total weight of the other elements present;
- (c) In this Section the term “ alloys ” includes sintered mixtures of metal powders, heterogeneous intimate mixtures obtained by melting (other than cermets) and intermetallic compounds.

8.-In this Section, the following expressions have the meanings hereby assigned to them :

(a) **Waste and scrap**

Metal waste and scrap from the manufacture or mechanical working of metals, and metal goods definitely not usable as such because of breakage, cutting-up, wear or other reasons.

(b) **Powders**

Products of which 90 % or more by weight passes through a sieve having a mesh aperture of 1 mm.

72. Iron and steel.

Chapter 72
Iron and steel

Notes.

1.- In this Chapter and, in the case of Notes (d), (e) and (f) throughout the Nomenclature, the following expressions have the meanings hereby assigned to them :

a) Pig iron

Iron-carbon alloys not usefully malleable, containing more than 2 % by weight of carbon and which may contain by weight one or more other elements within the following limits :

- not more than 10 % of chromium
- not more than 6 % of manganese
- not more than 3 % of phosphorus
- not more than 8 % of silicon
- a total of not more than 10 % of other elements.

b) Spiegeleisen

Iron-carbon alloys containing by weight more than 6 % but not more than 30 % of manganese and otherwise conforming to the specification at (a) above.

c) Ferro-alloys

Alloys in pigs, blocks, lumps or similar primary forms, in forms obtained by continuous casting and also in granular or powder forms, whether or not agglomerated, commonly used as an additive in the manufacture of other alloys or as de-oxidants, de-sulphurising agents or for similar uses in ferrous metallurgy and generally not usefully malleable, containing by weight 4 % or more of the element iron and one or more of the following:

- more than 10 % of chromium
- more than 30 % of manganese
- more than 3 % of phosphorus
- more than 8 % of silicon
- a total of more than 10 % of other elements, excluding carbon, subject to a maximum content of 10 % in the case of copper.

d) Steel

Ferrous materials other than those of heading 72.03 which (with the exception of certain types produced in the form of castings) are usefully malleable and which contain by weight 2 % or less of carbon. However, chromium steels may contain higher proportions of carbon.

e) Stainless steel

Alloy steels containing, by weight, 1.2 % or less of carbon and 10.5 % or more of chromium, with or without other elements.

(f) Other alloy steel

Steels not complying with the definition of stainless steel and containing by weight one or more of the following elements in the proportion shown :

- 0.3 % or more of aluminium
- 0.0008 % or more of boron
- 0.3 % or more of chromium
- 0.3 % or more of cobalt
- 0.4 % or more of copper
- 0.4 % or more of lead
- 1.65 % or more of manganese
- 0.08 % or more of molybdenum
- 0.3 % or more of nickel
- 0.06 % or more of niobium
- 0.6 % or more of silicon
- 0.05 % or more of titanium
- 0.3 % or more of tungsten (wolfram)
- 0.1 % or more of vanadium
- 0.05 % or more of zirconium
- 0.1 % or more of other elements (except sulphur, phosphorus, carbon and nitrogen), taken separately.

(g) Re-melting scrap ingots of iron or steel

Products roughly cast in the form of ingots without feeder-heads or hot tops, or of pigs, having obvious surface faults and not complying with the chemical composition of pig iron, spiegeleisen or Ferro-alloys.

(h) Granules

Products of which less than 90 % by weight passes through a sieve with a mesh aperture of 1 mm and of which 90 % or more by weight passes through a sieve with a mesh aperture of 5 mm.

73. Articles of iron or steel.

73.08		Structures (excluding prefabricated buildings of heading 94.06) and parts of structures (for example, bridges and bridge-sections, lock-gates, towers, lattice masts, roofs, roofing frame-works, doors and windows and their frames and thresholds for doors, shutters, balustrades, pillars and columns), of iron pillars and columns), of iron or steel; plates, rods, angles, shapes, sections, tubes and the like, prepared for use in structures, of iron or steel.
	7308.10	- Bridges and bridge-sections
	7308.20	- Towers and lattice masts
	7308.30	- Doors, windows and their frames and thresholds for doors
	7308.40	- Equipment for scaffolding, shuttering, propping or pit-propping
	7308.90	- Other
	7308.90.10	--- Industrial racking systems
	7308.90.90	--- Other

PRODUCT DESCRIPTION : INSULATED ROOF PANELS (THEY ARE COMPRISED OF RIGID POLYURETHANE SANDWICHED BETWEEN A STEEL SHEET AND A FIRE RETARDANT PVC LAYER)

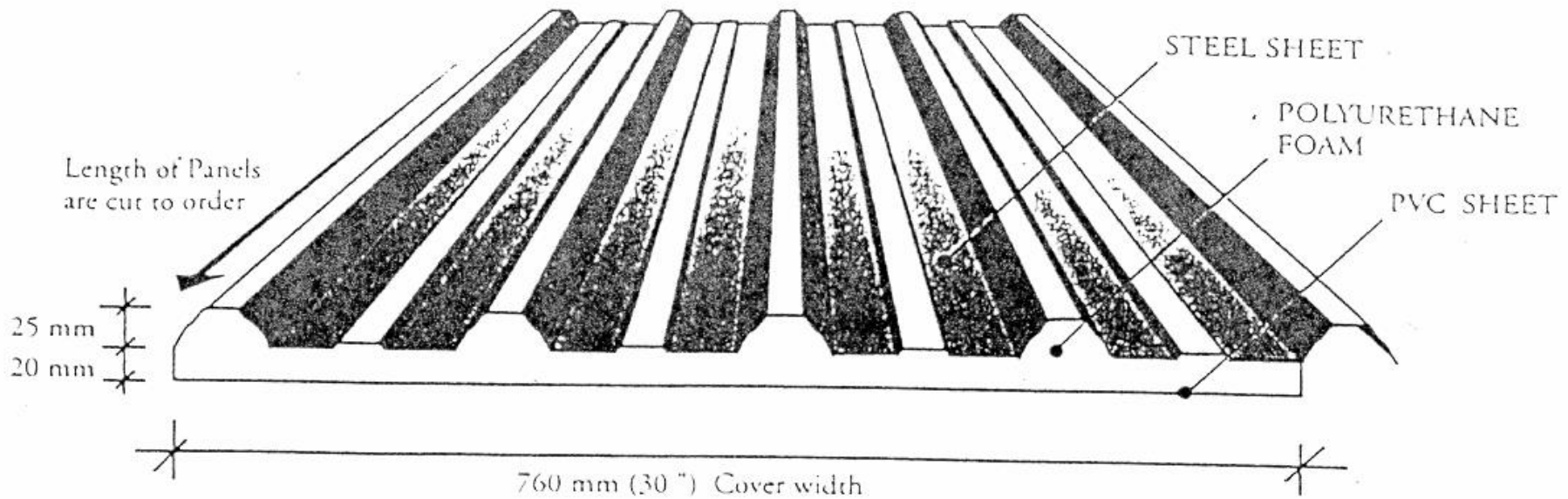

7308.90

73.19		Sewing needles, knitting needles, bodkins, crochet hooks, embroidery stiletos and similar articles, for use in the hand, or iron or steel; safety pins and other pins of iron or steel, not elsewhere specified or included.
	7319.20	- Safety pins
	7319.30	- Other pins
	7319.90	- Other :
	7319.90.10	--- Sewing, darning or embroidery needles
	7319.90.90	--- Other
73.21		Stoves, ranges, grates, cookers (including those with subsidiary boilers for central heating), barbecues, braziers, gas-rings, plate warmers and similar non-electric domestic appliances, and parts thereof, of iron or steel.
		- Cooking appliances and plate warmers :
	7321.11	-- For gas fuel or for both gas and other fuels
	7321.12	-- For liquid fuel
	7321.19	-- Other, including appliances for solid fuel
		- Other appliances :
	7321.81	-- For gas fuel or both gas and other fuels
	7321.82	-- For liquid fuel
	7321.89	-- Other, including appliances for solid fuel
	7321.90	- Parts

PRODUCT DESCRIPTION : **ARTICLE REFERRED TO AS 'TOILET PAPER AND WATER CLOSET (WC) BRUSH STAND' (IT CONSISTS OF A METAL STAND, A BRUSH (MADE OF PLASTICS) AND ITS CASE , A HANGER FOR TOILET PAPER AND FITTINGS FOR HANGING THESE ARTICLES**

73.24

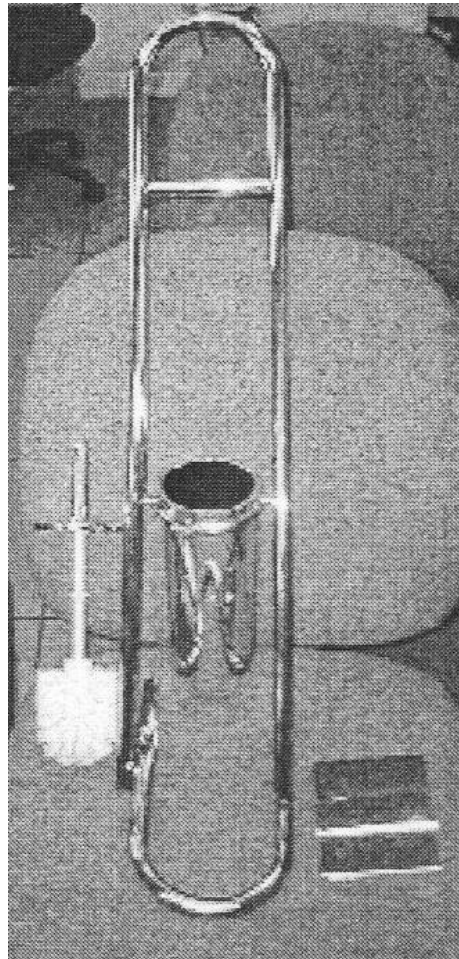

74. Copper and articles thereof.

Subheading Note.

1.- In this Chapter the following expressions have the meanings hereby assigned to them :

(a) Copper-zinc base alloys (brasses)

Alloys of copper and zinc, with or without other elements. When other elements are present :

- zinc predominates by weight over each of such other elements;
- any nickel content by weight is less than 5% (see copper-nickel-zinc alloys (nickel silvers)); and
- any tin content by weight is less than 3% (see copper-tin alloys (bronzes)).

(b) Copper-tin base alloys (bronzes)

Alloys of copper and tin, with or without other elements. When other elements are present, tin predominates by weight over each of such other elements, except that when the tin content is 3% or more the zinc content by weight may exceed that of tin but must be less than 10%.

(c) Copper-nickel-zinc base alloys (nickel silvers)

Alloys of copper, nickel and zinc, with or without other elements. The nickel content is 5% or more by weight (see copper-zinc alloys (brasses)).

(d) Copper-nickel base alloys

Alloys of copper and nickel, with or without other elements but in any case containing by weight not more than 1% of zinc. When other elements are present, nickel predominates by weight over each of such other elements.

74.01	7401.00	Copper mattes; cement copper (precipitated copper).
74.02	7402.00	Unrefined copper; copper anodes for electrolytic refining.
74.03		Refined copper and copper alloys, unwrought.
74.04	7404.00	Copper waste and scrap.
74.05	7405.00	Master alloys of copper.
74.06		Copper powders and flakes.
74.07		Copper bars, rods and profiles.
74.08		Copper wire.
74.09		Copper plates, sheets and strip, of a thickness exceeding 0.15 mm.
74.10		Copper foil (whether or not printed or backed with paper, paperboard, plastics or similar backing materials) of a thickness (excluding any backing) not exceeding 0.15 mm.
74.11		Copper tubes and pipes.
74.12		Copper tube or pipe fittings (for example, couplings, elbows, sleeves).
74.13	7413.00	Stranded wire, cables, plaited bands and the like, of copper, not electrically insulated.

[74.14]		
74.15		Nails, tacks, drawing pins, staples (other than those of heading 83.05) and similar articles, of copper or of iron or steel with heads of copper; screws, bolts, nuts, screw hooks, rivets, cotters, cotter-pins, washers (including spring washers) and similar articles, of copper (+).
[74.16]		
[74.17]		
74.18		Table, kitchen or other household articles and parts thereof, of copper; pot scourers and scouring or polishing pads, gloves and the like, of copper; sanitary ware and parts thereof, of copper.
74.19		Other articles of copper (+).
	7419.10	- Chain and parts thereof
		- Other :
	7419.91	-- Cast, moulded, stamped or forged, but not further worked
	7419.99	-- Other :
	7419.99.10	--- Electroplating anodes
	7419.99.20	--- Endless bands for machinery
	7419.99.30	--- Cloth (excluding endless bands for machinery), grill and netting, of copper wire; expanded metal of copper
	7419.99.40	--- Copper springs
	7419.99.90	--- Other

75. Nickel and articles thereof.

76. Aluminium and articles thereof.

77. *(Reserved for possible future use in the Harmonized System)*

78. Lead and articles thereof.

79. Zinc and articles thereof.

80. Tin and articles thereof.

81. Other base metals; cermets; articles thereof.

82. Tools, implements, cutlery, spoons and forks, of base metal; parts thereof of base metal.

82.01	Hand tools, the following: spades, shovels, mattocks, picks, hoes, forks and rakes; axes, bill hooks and similar hewing tools; secateurs and pruners of any kind; scythes, sickles, hay knives, hedge shears, timber wedges and other tools of a kind used in agriculture, horticulture or forestry.
82.02	Hand saws; blades for saws of all kinds (including slitting, slotting or toothless saw blades).
82.03	Files, rasps, pliers (including cutting pliers), pincers, tweezers, metal cutting shears, pipe-cutters, bolt croppers, perforating punches and similar hand tools.
82.04	Hand-operated spanners and wrenches (including torque meter wrenches but not including tap wrenches); interchangeable spanner sockets, with or without handles.

82.05		Hand tools (including glaziers' diamonds), not elsewhere specified or included; blow lamps; vices, clamps and the like, other than accessories for and parts of, machine tools; anvils; portable forges; hand or pedal-operated grinding wheels with frameworks.
	8205.10	- Drilling, threading or tapping tools
	8205.20	- Hammers and sledge hammers
	8205.30	- Planes, chisels, gouges and similar cutting tools for working wood
	8205.40	- Screwdrivers
		- Other hand tools (including glaziers' diamonds) :
	8205.51	-- Household tools
	8205.59	-- Other
	8205.60	- Blow lamps
	8205.70	- Vices, clamps and the like
	8205.80	- Anvils; portable forges; hand or pedal-operated grinding wheels with frameworks
	8205.90	- Sets of articles of two or more of the foregoing subheadings
82.06	8206.00	Tools of two or more of the headings 82.02 to 82.05, put up in sets for retail sale.

83. Miscellaneous articles of base metal.

83.07		Flexible tubing of base metal, with or without fittings.
	8307.10	- Of iron or steel
	8307.90	- Of other base metal
83.08		Clasps, frames with clasps, buckles, buckle-clasps, hooks, eyes, eyelets and the like, of base metal, of a kind used for clothing, footwear, awnings, hand bags, travel goods or other made up articles; tubular or bifurcated rivets, of base metal; beads and spangles, of base metal.
	8308.10	- Hooks, eyes and eyelets
	8308.20	- Tubular or bifurcated rivets
	8308.90	- Other, including parts

SECTION XVI

MACHINERY AND MECHANICAL APPLIANCES; ELECTRICAL EQUIPMENT; PARTS THEREOF; SOUND RECORDERS AND REPRODUCERS, TELEVISION IMAGE AND SOUND RECORDERS AND REPRODUCERS, AND PARTS AND ACCESSORIES OF SUCH ARTICLES

Section Notes

- I. This Section does not cover:
 - (a) Transmission or conveyor belts or belting, of plastics of Chapter 39, or of vulcanised rubber (heading 40.10); or other articles of a kind used in machinery or mechanical or electrical appliances or for other technical uses, of vulcanised rubber other than hard rubber (heading 40.16);
 - (b) Articles of leather or of composition leather (heading 42.05) or of furskin (heading 43.03), of a kind used in machinery or mechanical appliances or for other technical uses;
 - (c) Bobbins, spools, cops, cones, cores, reels or similar supports, of any material (for example, Chapter 39, 40, 44 or 48 or Section XV);
 - (d) Perforated cards for Jacquard or similar machines (for example, Chapter 39 or 48 or Section XV);
 - (e) Transmission or conveyor belts or belting of textile material (heading 59.10) or other articles of textile material for technical uses (heading 59.11);
 - (f) Precious or semi-precious stones (natural, synthetic or reconstructed) of headings 71.02 to 71.04, or articles wholly of such stones of heading 71.16, except unmounted worked sapphires and diamonds for styli (heading 85.22);

- (g) Parts of general use, as defined in Note 2 to Section XV, of base metal (Section XV), or similar goods of plastics (Chapter 39);
- (h) Drill pipe (heading 73.04);
- (ij) Endless belts of metal wire or strip (Section XV);
- (k) Articles of Chapter 82 or 83;
- (l) Articles of Section XVII;
- (m) Articles of Chapter 90;
- (n) Clocks, watches or other articles of Chapter 91;
- (o) Interchangeable tools of heading 82.07 or brushes of a kind used as parts of machines (heading 96.03); similar interchangeable tools are to be classified according to the constituent material of their working part (for example, in Chapter 40, 42, 43, 45 or 59 or heading 68.04 or 69.09);
- (p) Articles of Chapter 95 or
- (q) Typewriter or similar ribbons, whether or not on spools or in cartridges (classified according to their constituent material, or in heading 96.12 if inked or otherwise prepared for giving impressions).

- 3.- Unless the context otherwise requires, composite machines consisting of two or more machines fitted together to form a whole and other machines designed for the purpose of performing two or more complementary or alternative functions are to be classified as if consisting only of that component or as being that machine which performs the principal function.
- 4.- Where a machine (including a combination of machines) consists of individual components (whether separate or interconnected by piping, by transmission devices, by electric cables or by other devices) intended to contribute together to a clearly defined function covered by one of the headings in Chapter 84 or Chapter 85, then the whole falls to be classified in the heading appropriate to that function.
- 5.- For the purposes of these Notes, the expression “ machine ” means any machine, machinery, plant, equipment, apparatus or appliance cited in the headings of Chapter 84 or 85.

84. Nuclear reactors, boilers, machinery and mechanical appliances; parts thereof.
85. Electrical machinery and equipment and parts thereof; sound recorders and reproducers, television image and sound recorders and reproducers, and parts and accessories of such articles.

Chapter 85

Electrical machinery and equipment and parts thereof; sound recorders and reproducers, television image and sound recorders and reproducers, and parts and accessories of such articles

Notes.

1. This Chapter does not cover :
 - a) Electrically warmed blankets, bed pads, foot-muffs or the like; electrically warmed clothing, footwear or ear pads or other electrically warmed articles worn on or about the person;
 - b) Articles of glass of heading 70.11;
 - c) Machines and apparatus of heading 84.86;
 - d) Vacuum apparatus of a kind used in medical, surgical, dental or veterinary purposes (Chapter 90); or
 - e) Electrically heated furniture of Chapter 94.

3. Heading 85.09 covers only the following electro-mechanical machines of the kind commonly used for domestic purposes:

- a) Floor polishers, food grinders and mixers, and fruit or vegetable juice extractors, of any weight;
- b) Other machines provided the weight of such machines does not exceed 20 kg.

The heading does not, however, apply to fans or ventilating or recycling hoods incorporating a fan, whether or not fitted with filters (heading 84.14), centrifugal clothes- dryers (heading 84.21), dish washing machines (heading 84.22), household washing machines (heading 84.50), roller or other ironing machines (heading 84.20 or 84.51), sewing machines (heading 84.52), electric scissors (heading 84.67) or to electro-thermic appliances (heading 85.16).

PRODUCT DESCRIPTION : DOORS, SHUTTERS OR ROLLING GRILLES OF DIFFERENT TYPES FOR CLOSING SHOP FRONTS, GARAGES, RECEPTION COUNTERS, ARCADES ETC (THE DOORS OR SHUTTERS ARE MADE OF METAL AND MAY BE OPENED AND CLOSED MANUALLY OR AUTOMATICALLY WITH AN ELECTRIC MOTOR)

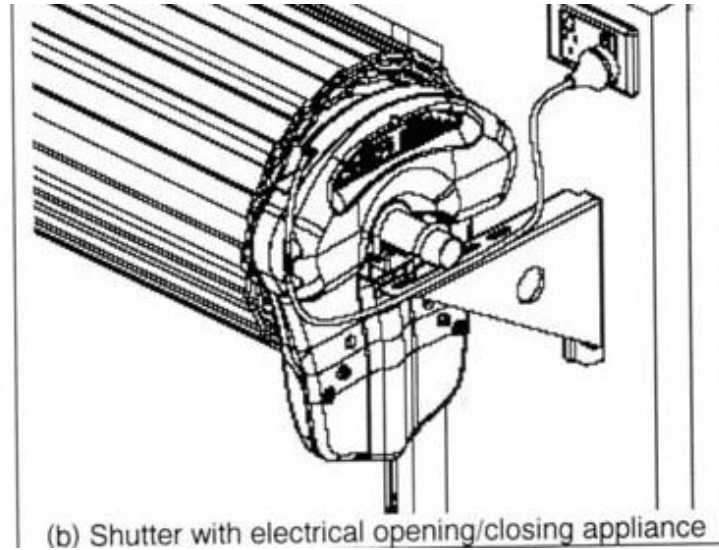
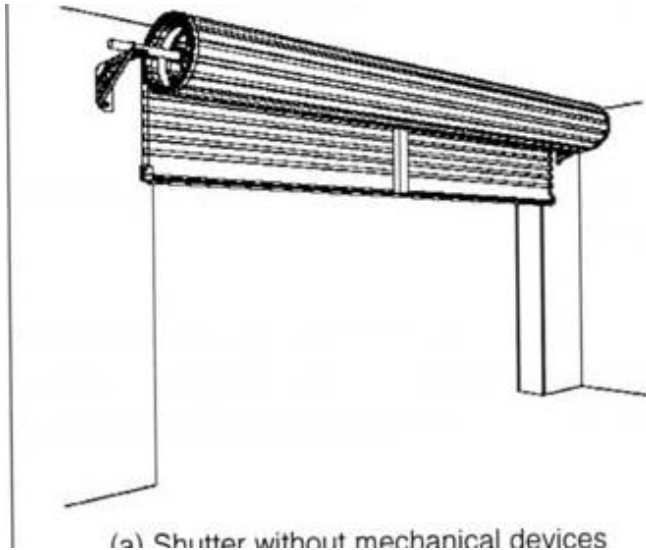

8479.89

PRODUCT DESCRIPTION : ELECTROMECHANICAL GEAR MOTOR FOR SLIDING GATES * (IT IS PRESENTED

IN ONE PACKAGE AT ONE TIME TO CUSTOMS AND CONTAIN MAINLY THE FOLLOWING : 2 COLUMNS, 2 PHOTOCELLS, A KEY SELECTOR OR DIGITAL KEYPAD, A CONTROL PANEL, A FLASHING LIGHT, AN AERIAL, A MOTOR AND A POWER SUPPLY LINE) **8479.89**

PRODUCT DESCRIPTION : ELECTROMECHANICAL ACTUATOR FOR HINGED GATES, WITH ONE OR TWO

WINGS, WITH JOINTED OR TELESCOPIC ARM * (IT IS PRESENTED IN ONE PACKAGE AT ONE TIME TO CUSTOMS AND CONTAIN MAINLY THE FOLLOWING :

2 COLUMNS, 2 PHOTOCELLS, A KEY SELECTOR OR DIGITAL KEYPAD, A CONTROL PANEL, A FLASHING LIGHT, AN AERIAL , 2MOTORS & A POWER SUPPLY LINE).

8479.89

PRODUCT DESCRIPTION : ELECTROMECHANICAL WINDOW OPENING MECHANISMS FOR MOTOR VEHICLES

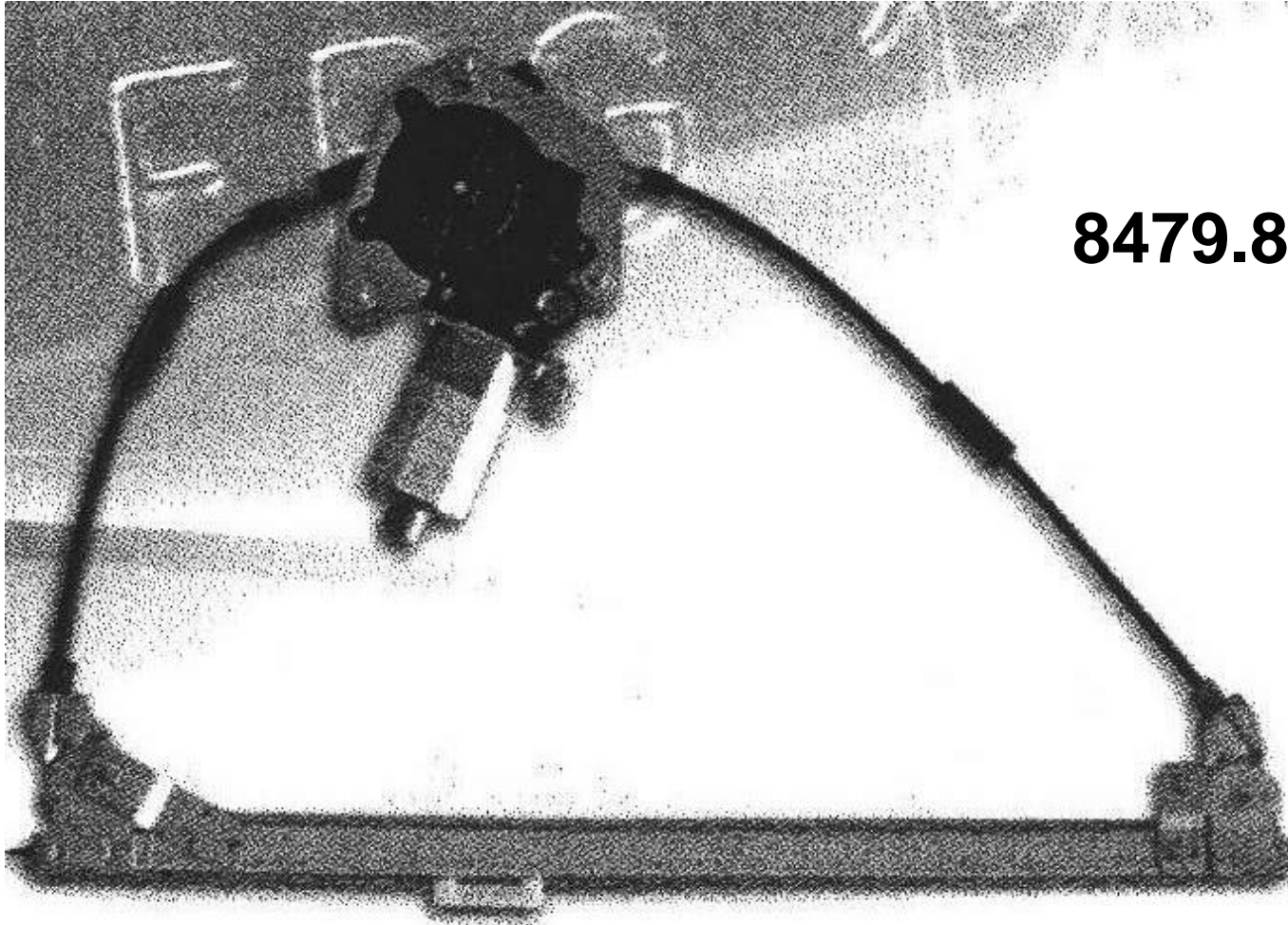

8479.89

85.13		Portable electric lamps designed to function by their own source of energy (for example, dry batteries, accumulators, magnetos), other than lighting equipment of heading 85.12.
85.27		Reception apparatus for radio-broadcasting, whether or not combined, in the same housing, with sound recording or reproducing apparatus or a clock.
		- Radio-broadcast receivers capable of operating without an external source of power :
	8527.12	-- Pocket-size radio cassette-players :
	8527.13	-- Other apparatus combined with sound recording or reproducing apparatus :
	8527.19	-- Other :
		- Radio-broadcast receivers not capable of operating without an external source of power, of a kind used in motor vehicles :
	8527.21	-- Combined with sound recording or reproducing apparatus
	8527.29	-- Other
		- Other :
	8527.91	-- Combined with sound recording or reproducing apparatus
	8527.92	-- Not combined with sound recording or reproducing apparatus but combined with a clock
	8527.99	-- Other

PRODUCT DESCRIPTION : 'LED' LAMPS



8543.70 (in 2012 version)
8539.50 - **Light –emitting diode (LED)**
lamps
(in 2017 version)



9405.40

SECTION XVII
VEHICLES, AIRCRAFT, VESSELS AND ASSOCIATED
TRANSPORT EQUIPMENT

Section notes.

- 2.- The expressions “ parts ” and “ parts and accessories ” do not apply to the following articles, whether or not they are identifiable as for the goods of this Section :
- (a) Joints, washers or the like of any material (classified according to their constituent material or in heading 84.84) or other articles of vulcanised rubber other than hard rubber (heading 40.16);
 - (b) Parts of general use, as defined in Note 2 to Section XV, of base metal (Section XV), or similar goods of plastics (Chapter 39);
 - (c) Articles of Chapter 82 (tools);
 - (d) Articles of heading 83.06;
 - (e) Machines or apparatus of headings 84.01 to 84.79, or parts thereof; articles of heading 84.81 or 84.82 or, provided they constitute integral parts of engines or motors, articles of heading 84.83;
 - (f) Electrical machinery or equipment (Chapter 85);
 - (g) Articles of Chapter 90;
 - (h) Articles of Chapter 91;
 - (ij) Arms (Chapter 93);
 - (k) Lamps or lighting fittings of heading 94.05; or
 - (l) Brushes of a kind used as parts of vehicles (heading 96.03).

4.- For the purposes of this Section :

- (a) Vehicles specially constructed to travel on both road and rail are classified under the appropriate heading of Chapter 87;
- (b) Amphibious motor vehicles are classified under the appropriate heading of Chapter 87;
- (c) Aircraft specially constructed so that they can also be used as road vehicles are classified under the appropriate heading of Chapter 88.

5.- Air-cushion vehicles are to be classified within this Section with the vehicles to which they are most akin as follows :

- (a) In Chapter 86 if designed to travel on a guide-track (hovertrains);
- (b) In Chapter 87 if designed to travel over land or over both land and water;

86. Railway or tramway locomotives, rolling-stock and parts thereof;
railway or tramway track fixtures and fittings and parts thereof;
mechanical (including electro-mechanical) traffic signaling equipment of all kinds.

87. Vehicles other than railway or tramway rolling-stock, and parts and accessories thereof.

88. Aircraft, spacecraft, and parts thereof.

89. Ships, boats and floating structures.

PRODUCT DESCRIPTION : **ALL TERRAIN VEHICLE (ATV)**
(FOUR-WHEELED VEHICLE WITH TUBE CHASSIS, EQUIPPED WITH A
MOTORCYCLE TYPE SADDLE, HNDLEBARS FOR STEERING AND
OFF-THE-ROAD BALLOON TYRES, POWERED BY AN SPARK
IGNITION ENGINE OF A CYLINDER CAPACITY BETWEEN 50 TO 750
CC



8703.21



PRODUCT DESCRIPTION : MOTOR YACHT (THE VESSEL AT ISSUE HAS A DECK, A SALOON EQUIPPED WITH A KITCHENETTE AND DINETTE SEATING, 2 DOUBLE CABINS EQUIPPED WITH WARDROBES AND PRIVATE BATHROOMS / IT HAS ALSO A FLY DRIDGE PROVIDING SEAT FOR SEVERAL PERSONS) * (LENGTH OVERALL : 13.53 M / DRY WEIGHT (APPROX.) : 12 TONS) **8903.92**



SECTION XVIII

OPTICAL, PHOTOGRAPHIC, CINEMATOGRAPHIC, MEASURING, CHECKING, PRECISION, MEDICAL OR SURGICAL INSTRUMENTS AND APPARATUS; CLOCKS AND WATCHES; MUSICAL INSTRUMENTS; PARTS AND ACCESSORIES THEREOF

Chapter 90. Optical, photographic, cinematographic, measuring, checking, precision, medical or surgical instruments and apparatus; parts and accessories thereof.

90.13 Liquid crystal devices not constituting articles provided for more specifically in other headings; lasers, other than laser diodes; other optical appliances and instruments, not specified or included elsewhere in this Chapter.

LASER POINTERS – 9013.20

DOOR –EYES - 9013.80

90.16	9016.00	Balances of a sensitivity of 5 cg or better, with or without weights. <i><u>(84.23 Weighing machinery, including weight operated or checking machines ;)</u></i>
-------	---------	--

90.17		Drawing, marking-out or mathematical calculating instruments (for example, drafting machines, pantographs, protractors, drawing sets, slide rules, disc calculators); instruments for measuring length, for use in the hand (for example, measuring rods and tapes, micrometers, calipers), not specified or included elsewhere in this Chapter.
	9017.10	- Drafting tables and machines, whether or not automatic
	9017.20	- Other drawing, marking-out or mathematical calculating instruments
	9017.20.10	--- Protractors (radius 10 cm and below)
	9017.20.20	--- Rulers 30 cm and below
	9017.20.30	--- Triangular set squares shortest side 17.5 cm or below
	9017.20.40	--- Dividers and compasses
	9017.20.50	--- Sets of mathematical instruments used by school children, with a ruler not exceeding 15 cm packed in metal or plastic
	9017.20.90	--- Other
	9017.30	- Micrometers, callipers and gauges
	9017.80	- Other instruments
	9017.90	- Parts and accessories

90.18

Instruments and appliances used in medical, surgical, dental or veterinary sciences, including scintigraphic apparatus, other electro-medical apparatus and sight-testing instruments (+).

- Electro-diagnostic apparatus (including apparatus for functional exploratory examination or for checking physiological parameters) :
 - 9018.11 -- Electro-cardiographs
 - 9018.12 -- Ultrasonic scanning apparatus
 - 9018.13 -- Magnetic resonance imaging apparatus
 - 9018.14 -- Scintigraphic apparatus
 - 9018.19 -- Other
- 9018.20 - Ultra-violet or infra-red ray apparatus
- Syringes, needles, catheters, cannulae and the like :
 - 9018.31 -- Syringes, with or without needles
 - 9018.32 -- Tubular metal needles and needles for sutures
 - 9018.39 -- Other
- Other instruments and appliances, used in dental sciences :
 - 9018.41 -- Dental drill engines, whether or not combined on a single base with other dental equipment
 - 9018.49 -- Other
- 9018.50 - Other ophthalmic instruments and appliances
- 9018.90 - Other instruments and appliances

Orthopaedic appliances, including crutches, surgical belts and trusses; splints and other fracture appliances; artificial parts of the body; hearing aids and other appliances which are worn or carried or implanted in the body, to compensate for a defect or disability.

90.21

9021.10 - Orthopaedic or fracture appliances

- Artificial teeth and dental fittings :

9021.21 -- Artificial teeth

9021.29 -- Other

- Other artificial parts of the body :

9021.31 -- Artificial joints

9021.39 -- Other

9021.40 - Hearing aids, excluding parts and accessories

9021.50 - Pacemakers for stimulating heart muscles, excluding parts and accessories

9021.90 - Other

90.22

Apparatus based on the use of X-rays or of alpha, beta or gamma radiations, whether or not for medical, surgical, dental or veterinary uses, including radiography or radiotherapy apparatus, X-ray tubes and other X-ray generators, high tension generators, control panels and desks, screens, examination or treatment tables, chairs and the like (+).

- Apparatus based on the use of X-rays, whether or not for medical, surgical, dental or veterinary uses, including radiography or radiotherapy apparatus :

9022.12 -- Computed tomography apparatus

9022.13 -- Other, for dental uses

9022.14 -- Other, for medical, surgical, or veterinary uses

9022.19 -- For other uses

- Apparatus based on the use of alpha, beta or gamma radiations, whether or not for medical, surgical, dental or veterinary uses, including radiography or radiotherapy apparatus :

9022.21 -- For medical, surgical, dental or veterinary uses

9022.29 -- For other uses

9022.30 - X-ray tubes

9022.90 - Other, including parts and accessories

***PRODUCT DESCRIPTION : LINEAR (PARTICLE) ACCELERATOR
FOR RADIOTHERAPY, PRESENTED AS A COMBINATION OF
MACHINES INTERCONNECTED BY ELECTRIC CABLES***



9022.14

91. Clocks and watches and parts thereof.

92. Musical instruments; parts and accessories of such articles.

SECTION XIX

ARMS AND AMMUNITION; PARTS AND ACCESSORIES THEREOF

93. Arms and ammunition; parts and accessories thereof.

SECTION XX

MISCELLANEOUS MANUFACTURED ARTICLES

94. Furniture; bedding, mattresses, mattress supports, cushions and similar stuffed furnishings; lamps and lighting fittings, not elsewhere specified or included; illuminated signs, illuminated name-plates and the like; prefabricated buildings.

Chapter 94

Furniture; bedding, mattresses, mattress supports, cushions and similar stuffed furnishings; lamps and lighting fittings, not elsewhere specified or included; illuminated signs, illuminated name-plates and the like; prefabricated buildings

Notes.

1. This Chapter does not cover :
 - a) Pneumatic or water mattresses, pillows or cushions, of Chapter 39, 40 or 63;
 - b) Mirrors designed for placing on the floor or ground (for example, cheval-glasses (swingmirrors)) of heading 70.09;
 - c) Articles of Chapter 71;
 - d) Parts of general use as defined in Note 2 to Section XV, of base metal (Section XV), or similar goods of plastics (Chapter 39), or safes of heading 83.03;
 - e) Furniture specially designed as parts of refrigerating or freezing equipment of heading 84.18; furniture specially designed for sewing machines (heading 84.52);
 - f) Lamps or lighting fittings of Chapter 85;
 - g) Furniture specially designed as parts of apparatus of heading 85.18 (heading 85.18), of headings 85.19 to 85.21 (heading 85.22) or of headings 85.25 to 85.28 (heading 85.29);
 - h) Articles of heading 87.14;

(ij) Dentists' chairs incorporating dental appliances of heading 90.18 or dentists' spittoons (heading 90.18);

(k) Articles of Chapter 91 (for example, clocks and clock cases); or

(l) Toy furniture or toy lamps or lighting fittings (heading 95.03), billiard tables or other furniture specially constructed for games (heading 95.04), furniture for conjuring tricks or decorations (other than electric garlands) such as Chinese lanterns (heading 95.05)

94.01		Seats (other than those of heading 94.02), whether or not convertible into beds, and parts thereof (+).
	9401.10	- Seats of a kind used for aircraft
	9401.10.10	--- Used
	9401.10.90	--- Other
	9401.20	- Seats of a kind used for motor vehicles
	9401.20.10	--- Used
	9401.20.90	--- Other
	9401.30	- Swivel seats with variable height adjustment
	9401.30.10	--- Used
	9401.30.90	--- Other
	9401.40	- Seats other than garden seats or camping equipment, convertible into beds
	9401.40.10	--- Used
	9401.40.90	--- Other
		- Seats of cane, osier, bamboo or similar materials :

	9401.51	--	Of bamboo or rattan
	9401.51.10	---	Used
	9401.51.90	---	Other
	9401.59	--	Other
	9401.59.10	---	Used
	9401.59.90	---	Other
		-	Other seats, with wooden frames :
	9401.61	--	Upholstered
	9401.61.10	---	Used
	9401.61.90	---	Other
	9401.69	--	Other
	9401.69.10	---	Used
	9401.69.90	---	Other
		-	Other seats, with metal frames :
	9401.71	--	Upholstered

94.02		Medical, surgical, dental or veterinary furniture (for example, operating tables, examination tables, hospital beds with mechanical fittings, dentists' chairs); barbers' chairs and similar chairs, having rotating as well as both reclining and elevating movements; parts of the foregoing articles.
94.03		Other furniture and parts thereof.
94.04		Mattress supports; articles of bedding and similar furnishing (for example, mattresses, quilts, eiderdowns, cushions, pouffes and pillows) fitted with springs or stuffed or internally fitted with any material or of cellular rubber or plastics,
94.05		Lamps and lighting fittings including searchlights and spotlights and parts thereof, not elsewhere specified or included; illuminated signs, illuminated name-plates and the like, having a permanently fixed light source, and parts thereof not elsewhere specified or included.

**PRODUCT DESCRIPTION : ARTICLES CALLED 'SOLAR LIGHT EMITTING TILES'
(SOLAR LIGHTING SYSTEMS**

CONSISTING OF MODULAR, SELF-CONTAINED LIGHTING DEVICES THAT CAN
BE USED FOR DECORATIVE OR PATH LIGHTING PURPOSES / THEY ARE
POWERED BY SOLAR ENERGY ALONE) * (BASIC COMPONENTS OF THE TILES :
SOLAR CELLS, 'PSEUDOCAPACITORS', LIGHT EMITTING DIODES, ELECTRONIC
'PSEUDOCAPACITORS', LIGHT EMITTING DIODES, ELECTRONIC
CONTROLLERS AND 'PSEUDOCAPACITORS', LIGHT EMITTING DIODES,
ELECTRONIC POLYCARBONATE

9405.40



95. Toys, games and sports requisites; parts and accessories thereof.

96. Miscellaneous manufactured articles.

Chapter 96

Miscellaneous manufactured articles

Notes.

1. This Chapter does not cover :

(a) Pencils for cosmetic or toilet uses (Chapter 33);

(b) Articles of Chapter 66 (for example, parts of umbrellas or walking sticks);

(c) Imitation jewellery (heading 71.17);

(d) Parts of general use, as defined in Note 2 to Section XV, of base metal (Section XV), or similar goods of plastics (Chapter 39);

- (e) Cutlery or other articles of Chapter 82 with handles or other parts of carving or moulding materials; heading 96.01 or 96.02 applies, however, to separately presented handles or other parts of such articles;
- (f) Articles of Chapter 90 (for example, spectacle frames (heading 90.03), mathematical drawing pens (heading 90.17), brushes of a kind specialized for use in dentistry or for medical, surgical or veterinary purposes (heading 90.18));
- (g) Articles of Chapter 91 (for example, clock or watch cases);
- (h) Musical instruments or parts or accessories thereof (Chapter 92);
- (ij) Articles of Chapter 93 (arms and parts thereof);
- (k) Articles of Chapter 94 (for example, furniture, lamps and lighting fittings);
- (l) Articles of Chapter 95 (toys, games, sports requisites); or
- (m) Works of art, collectors' pieces or antiques (Chapter 97).

96.01		Worked ivory, bone, tortoise-shell, horn, antlers, coral, mother-of-pearl and other animal carving material, and articles of these materials (including articles obtained by moulding).
	9601.10	- Worked ivory and articles of ivory
	9601.90	- Other :
	9601.90.10	--- Coral and mother-of-pearl
	9601.90.90	--- Other

96.03		Brooms, brushes (including brushes constituting parts of machines, appliances or vehicles), hand-operated mechanical floor sweepers, not motorised, mops and feather dusters; prepared knots and tufts for broom or brush making; paint pads and rollers; squeegees (other than roller squeegees).
	9603.10	- Brooms and brushes, consisting of twigs or other vegetable materials bound together, with or without handles :
	9603.10.10	--- Brooms made of coconut fibre
	9603.10.20	--- Brooms made of other fibre
	9603.10.30	--- Tawashi brushes made of 100% coconut fibre
	9603.10.40	--- Tawashi brushes made of coconut fibre mixed with other vegetable fibre
	9603.10.50	--- Tawashi brushes made of coir fibre mixed with artificial fibre
	9603.10.60	--- Other brushes made of coconut fibre
	9603.10.70	--- Brushes made of other fibre
		- Tooth brushes, shaving brushes, hair brushes, nail brushes, eyelash brushes and other toilet brushes for use on the person, including such brushes constituting parts of appliances:
	9603.21	-- Tooth brushes, including dental-plate brushes
	9603.29	-- Other
	9603.30	- Artists' brushes, writing brushes and similar brushes for the application of cosmetics
	9603.40	- Paint, distemper, varnish or similar brushes (other than brushes of subheading 9603.30); paint pads and rollers
	9603.50	- Other brushes constituting parts of machines, appliances or vehicles
	9603.90	- Other

96.04	9604.00	Hand sieves and hand riddles.
96.05	9605.00	Travel sets for personal toilet, sewing or shoe or clothes cleaning.
96.09		Pencils (other than pencils of heading 96.08), crayons, pencil leads, pastels, drawing charcoals, writing or drawing chalks and tailors' chalks.
	9609.10	- Pencils and crayons, with leads encased in a rigid sheath :
	9609.10.10	--- Black lead pencils
	9609.10.20	--- Colour pencils
	9609.10.30	--- Crayons
	9609.20	- Pencil leads, black or coloured :
	9609.20.10	--- Black
	9609.20.20	--- Coloured
	9609.90	- Other
96.14	9614.00	Smoking pipes (including pipe bowls) and cigar or cigarette holders, and parts thereof.

96.15		Combs, hair-slides and the like; hairpins, curling pins, curling grips, hair-curlers and the like, other than those of heading 85.16, and parts thereof.
		- Combs, hair-slides and the like :
	9615.11	-- Of hard rubber or plastics
	9615.19	-- Other
	9615.90	- Other

SECTION XXI

WORKS OF ART, COLLECTORS' PIECES AND ANTIQUES

97. Works of art, collectors' pieces and antiques.

Chapter 97

Works of art, collectors' pieces and antiques

Notes.

1. This Chapter does not cover :

- (a) Unused postage or revenue stamps, postal stationery (stamped paper) or the like, of heading 49.07;
- (b) Theatrical scenery, studio back-cloths or the like, of painted canvas (heading 59.07) except if they may be classified in heading 97.06; or
- (c) Pearls, natural or cultured, or precious or semi-precious stones (headings 71.01 to 71.03).

97.04	9704.00	Postage or revenue stamps, stamp-postmarks, first-day covers, postal stationery (stamped paper), and the like, used or unused, other than those of heading 49.07.
-------	---------	---

98. *(Reserved for special uses by Contracting Parties)*

99. *(Reserved for special uses by Contracting Parties)*

SHIPPERS' ACADEMY COLOMBO



ACADEMY FOR

COMMERCE + LOGISTICS

Thank you